

## BOWL LIFTER PE 130-160

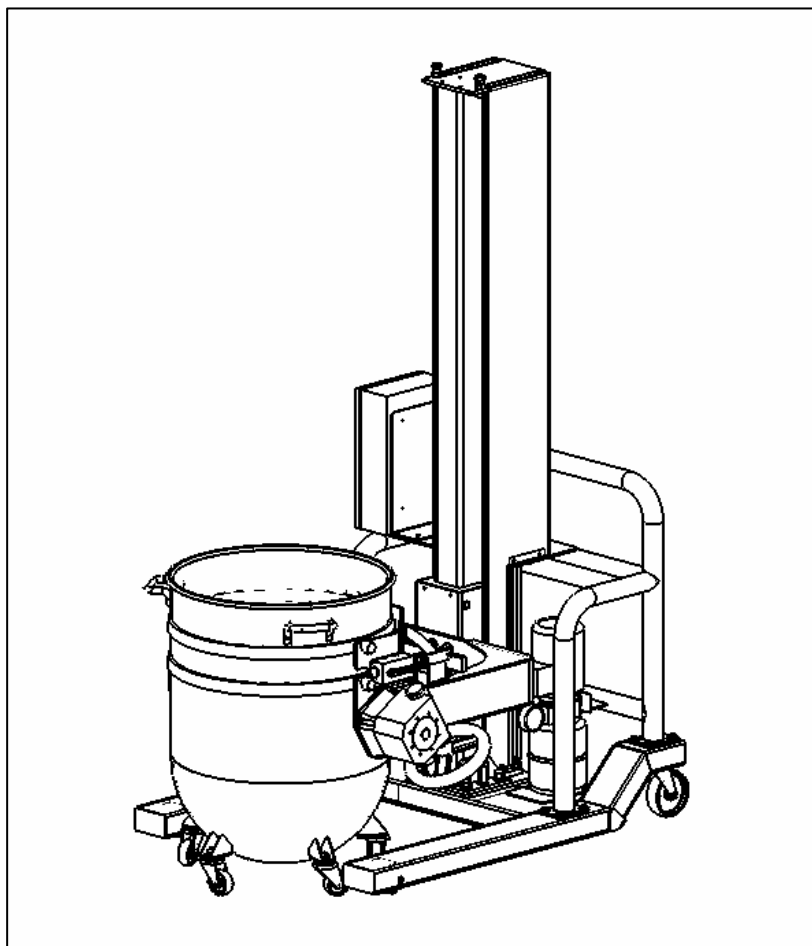

## STANDARDS

The equipment conforms to the following european standards:

- EN 292, EN 294, CEI 17-13, EEC directives: 89/392/CEE, 89/336/CEE, 91/368/CEE, 93/44 CEE, 93/68 CEE.

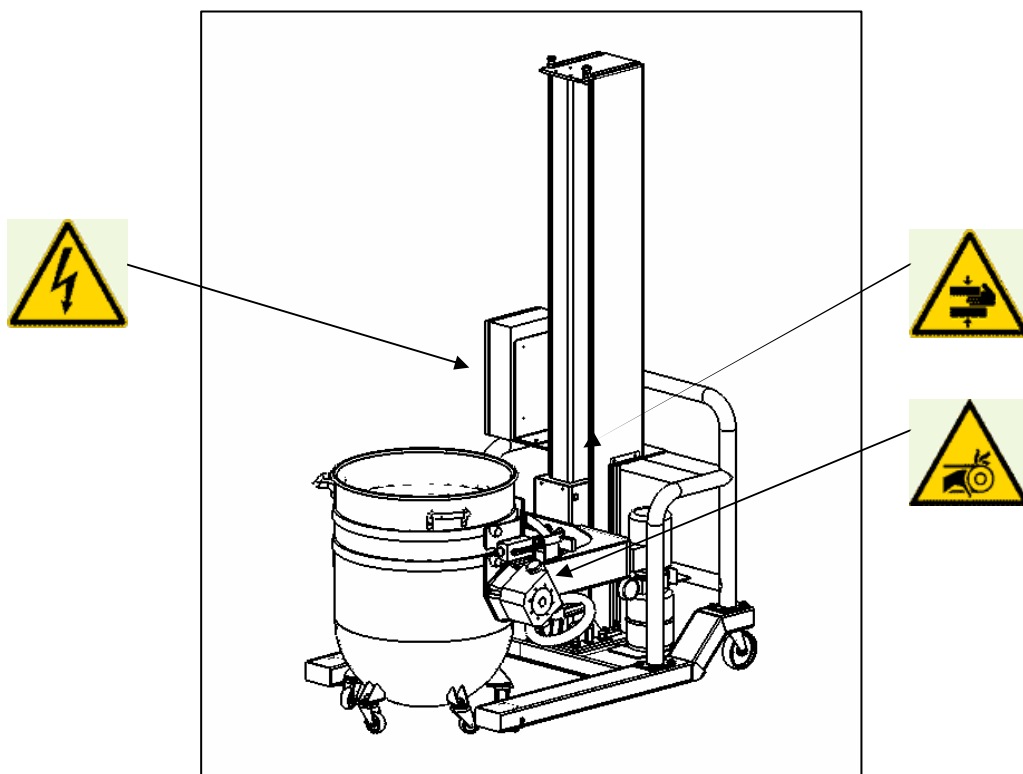

## GENERAL INFORMATION

The lifter is made of heavy duty welded metal sheet with a core s/steel column to lift the bowl holder.

The lifter is featured with an hydraulic lifting system, the bowl tilting is controlled manually by means of a reduction gearing system.

PE130-160 is easy to handle thanks to the four wheels (swivel wheels in the back)

The equipment is identified by the rear technical tag which includes the technical specifications and the serial no.

# OVERALL DIMENSIONS, CRATE HANDLING

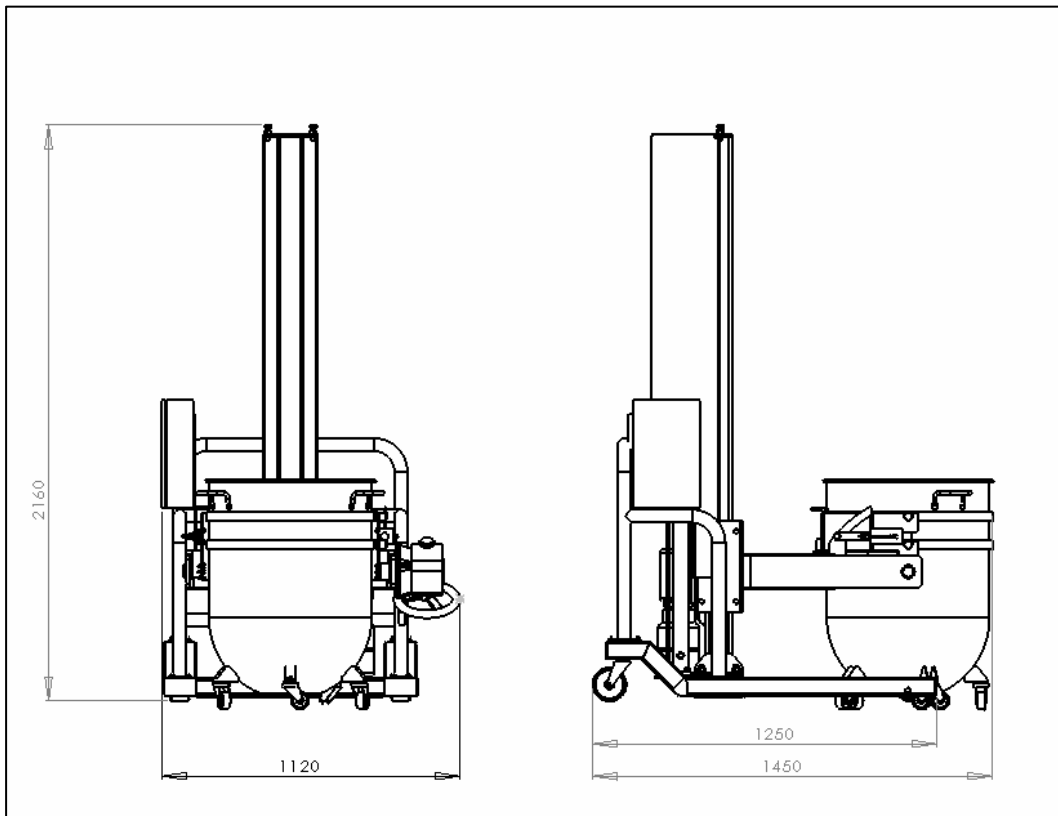
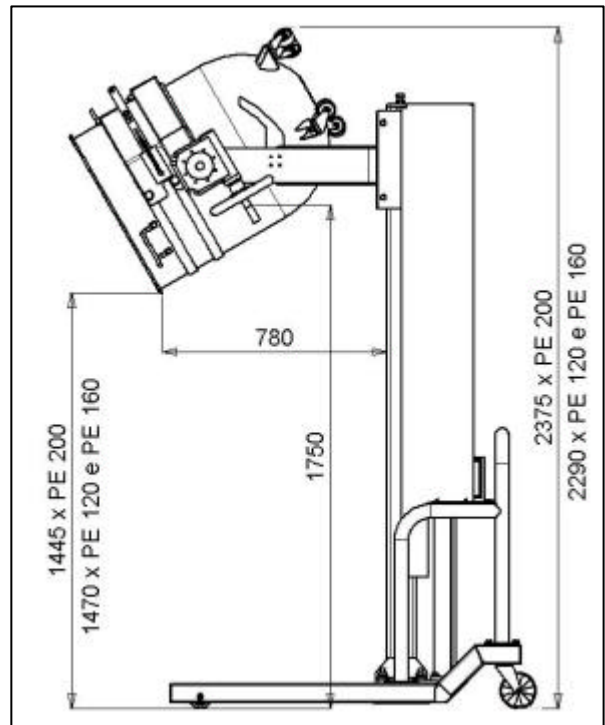
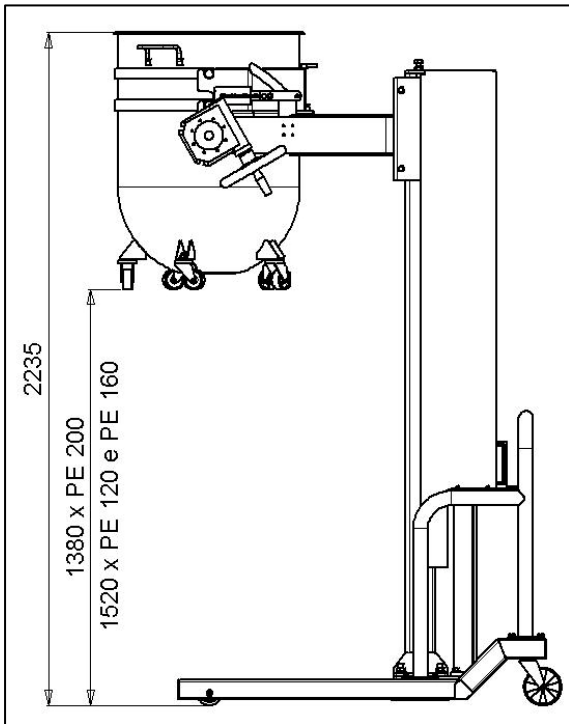

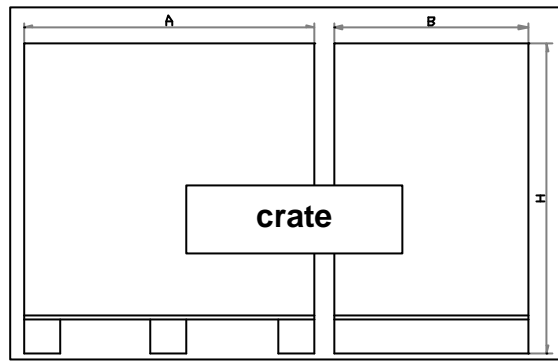

Net weight Kgs	Gross weight Kgs	Crate dimensions	Power	Tension
		a x b x h (mm.)		
320	400	2800 x 1250 x h.1400	1,5Kw	400V -3ph-50Hz

## CONTROL BOARD

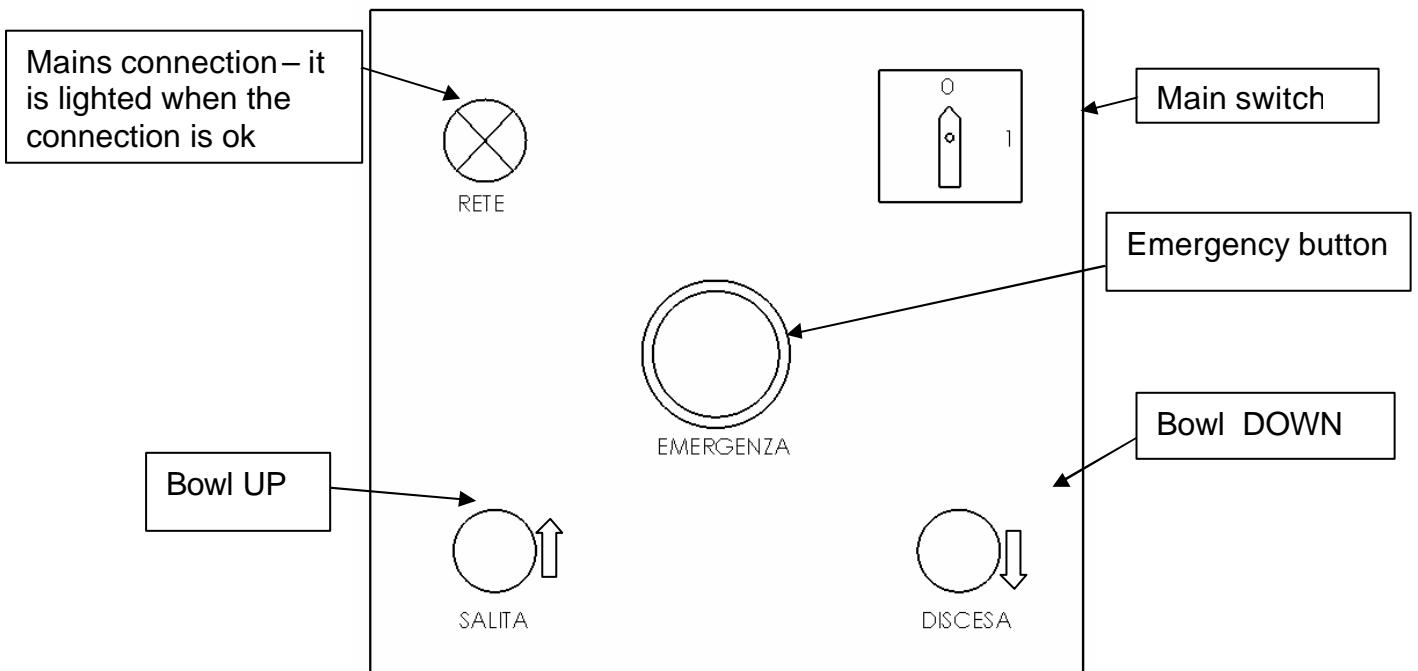

After switching ON the main switch verify the correct position of the bowl and **make sure the bowl is securely fastened to the bowl holder.**

Use the UP and DOWN buttons to move up and down the bowl, use the wheel to discharge the content.

## WARRANTY

Manufacturer's warranty covers the equipment for 12 months from factory delivery with the following limitations: all mechanic parts are covered by the warranty(unless a wrong use of the machine is proven), electric and electronic parts are excluded.

Spare parts are supplied on ex-works basis, labour costs always excluded

## SPARE PARTS

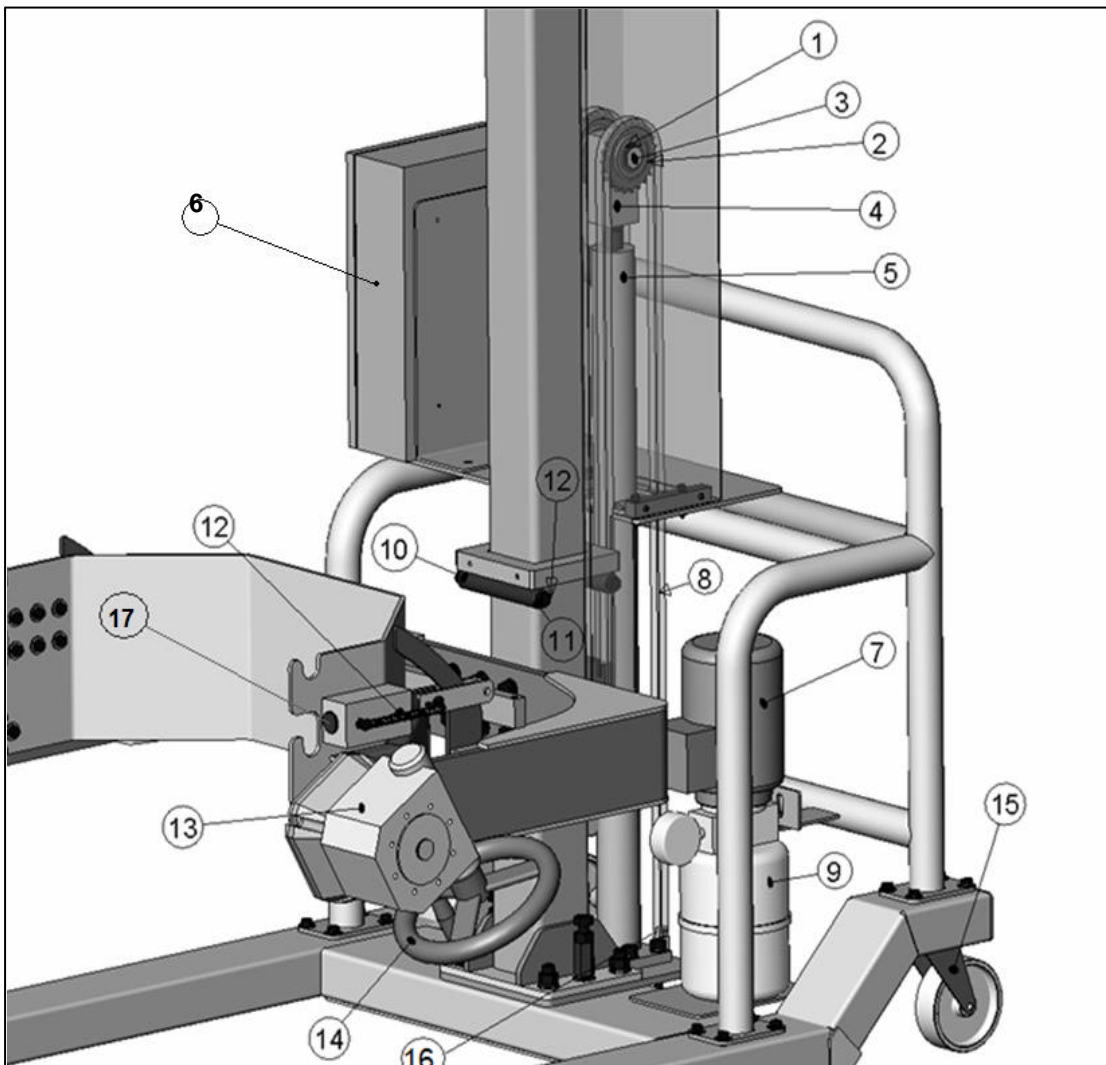

Ref.	Code	Description	Q.ty
1	Open market	BEARING N° 6206	2
2	183036	CYLINDER RIM	2
3	183035	CYLINDER RIM PIN	1
4	183034	PISTON FORK	1
5	183031	KIT CYLINDER SHAFT 28-STROKE 800	1
6	Open market	ELECTRIC BOX	1
7	Open market	MOTOR GR 71 - FLANGE B14	1
8	Open market	CHAIN 1/ 2 x 5/16	2
9		HYDRAULIC UNIT	1
10	183029	LIFTING SLIDING TUBE	4
11	183030	INNER STRUCTURE FOR SLIDING TUBE	4
12	Open market	BUSH KU 18 x 20 x 25	8
13		REDUCTION GEARING BOX	1
14	183055	DISCHARGE WHEEL Ø250	1
15	Open market	HEAVY DUTY SWIVEL WHEEL 125 x 40	
16	183033	CHAIN FASTENING KIT	2
17	183043-1	BRAKE PIN	2

## WHAT IF

PROBLEM	POSSIBLE SOLUTION
The main switch is ON but the machine doesn't work	<ul style="list-style-type: none"> <li>- check plug n socket</li> <li>- check plug wire connections</li> <li>- check protection positions</li> <li>- check microswitch</li> </ul>
Intermittent noise	- verify if some components need lubrication
Continual noise	- verify bearings

# ELECTRIC SCHEME

