

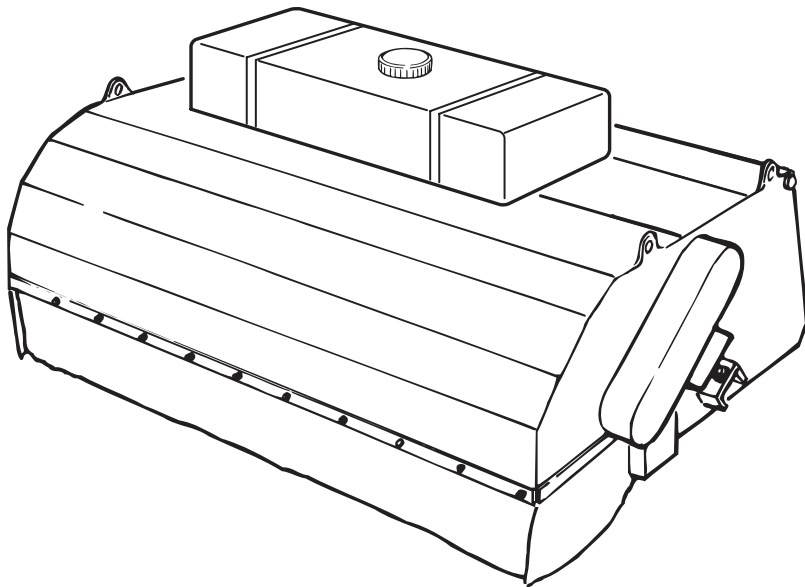

SPAZZATRICE "MANTA"
SWEeper "MANTA"
BALAYEUSE "MANTA"
BARREDORA "MANTA"



Rev. 4 - 01/2012

CATALOGO PARTI DI RICAMBIO
SPARE PARTS CATALOGUE
CATALOGUE DE PIECES DETACHEES
CATALOGO DE PIEZAS DE REPUESTO



SIMBOLOGIA • SIMBOLS • SYMBOLES UTILISES • SIMBOLOGIA

I

Nella colonna Note di ogni distinta può essere presente uno di questi simboli:



Parte di ricambio momentaneamente priva di codice.

Per identificarla occorre indicare:

- Numero della tavola
- Numero di posizione
- Modello e matricola della macchina.



Parte di ricambio rappresentata anche in questa tavola, ma il cui codice è riportato in altra tavola.

Per identificarla occorre andare alla tavola il cui numero di riferimento è scritto nella sola colonna **Denominazione** (in italiano).



Parte di ricambio avente ulteriori parti di ricambio interne.

Per identificare le singole parti interne occorre andare alla tavola di corrispondente denominazione.



Parte di ricambio con variabili dimensionali.

Occorre specificare il modello e la matricola della macchina individuabili nell'apposita targhetta.

GB

In the Remarks column of each list, you can find one of following symbols:



Spare part temporarily without a code.

To identify the part you must specify:

- Table code
- The position number
- Machine model and serial number.



Spare part which is shown in this Plate but whose code number is specified in another Plate.

To identify the replacement part you must go to the Plate whose reference number is given only in the **Denominazione** column (in Italian).



Replacement part with other replacement parts inside it.

In order to find the single internal parts, please refer to the relevant description table.



Spare part with dimension variables.

The machine model and serial number, given in the identification plate, shall be always specified.

F

La colonna Notes de chaque liste peut être complétée par un des symboles suivants:



Pièce de rechange momentanément privée de code.

Per identificarla occorre indicare:

- Code tableau
- Numéro de position
- Modèle et numéro de fabrique machine.



Pièce de rechange représentée dans le tableau en question mais dont le code est reporté dans un autre tableau.

Pour l'identifier il convient de se reporter au tableau dont le numéro de référence est inscrit exclusivement dans la colonne **Denominazione** (en italien).



Pièce de rechange possédant elle-même des pièces de rechange internes.

Pour l'identification de pièces individuelles, se référer au tableau descriptif correspondant.



Pièce détachée avec variables dimensionnelles.

Spécifier toujours le modèle et le numéro de fabrique de la machine, donnés sur la plaque d'identification.

E

La columna Notas de cada lista puede presentar uno de los símbolos siguientes:



Repuesto actualmente falto de código.

Para la identificación del repuesto es necesario indicar:

- Código tabla
- Número de posición
- Modelo y número de serie máquina.



Repuesto representado también en esta tabla, pero el código relativo se detalla en otra tabla.

Para la identificación es necesario consultar la tabla que lleva el número de referencia escrito en la sola columna **Denominazione** (en italiano).



Ruesto que consta de sucesivos repuestos internos.

Por la identificación de las partes internas distintas, ver tabla descriptiva correspondiente.



Repuesto con variables dimensionales.

Declarar siempre el modelo y el número de serie de la máquina, que se encuentran en la tarjeta de identificación.

COME ORDINARE I RICAMBI • HOW TO ORDER SPARE PARTS • COMMANDE DES PIÈCES DÉTACHÉES PEDIDO DE LOS REPUESTOS

Per ordinare le parti di ricambio Vi preghiamo cortesemente di fornire al Servizio Assistenza U.Emme tutte le seguenti informazioni:

- Modello, tipo e numero di matricola della macchina.
- Codice, descrizione e quantità delle parti di ricambio che si intendono ordinare.

Inoltre all'ordine sarà necessario precisare:

- Ragione sociale, indirizzo completo, recapito telefonico e telefax.
- Indirizzo completo al quale spedire le parti di ricambio.
- Eventuale mezzo di trasporto/vettore da utilizzare preferenzialmente.

When ordering spare parts please provide the U.Emme After Sales Service with all the following information:

- Machine model, type and serial number
- Code, description and quantity of the spare parts required.

The following information must also be specified on the order:

- Your company name, full address, telephone and fax number.
- Full address to which the spare parts are to be sent.
- Your preference with regard to the mode of transport/carrier.

Pour commander les pièces de rechange nous vous prions de bien vouloir transmettre au Service d'Assistance U.Emme les indications suivantes:

- Modèle, type et numéro de série de la machine.
- Code, description et quantité des pièces de rechange commandées.

Par ailleurs il est nécessaire d'indiquer dans la commande:

- Nom de la société, adresse complète, numéro de téléphone et de téléfax.
- Adresse complète pour l'expédition.
- Eventuellement, moyen de transport à utiliser de préférence.

Para el pedido de repuestos, Le rogamos se sirvan suministrar al Servicio Asistencia U.Emme todas las indicaciones siguientes:

- Modelo, tipo y número de matrícula de la máquina.
- Código, descripción y cantidad de los repuestos pedido.

Además, se ruega detallar lo siguiente:

- Razón social, dirección completa, teléfono y telefax.
- Dirección completa a la que se deben enviar los repuestos.
- Eventual medio/agente de transporte que se desea utilizar.

INDICE DELLE TAVOLE • INDEX OF PLATES • INDEX DES TABLEAUX • INDICE DE LAS TABLAS

Tav. 1	Benna raccolta con spazzola (version HD)	Bucket with brush (version HD)	Godet avec balai (HD version)	Cuchara con cepillo (versión HD)
Tav. 2	Benna raccolta con spazzola 2500 HD	Bucket with brush 2500 HD	Godet avec balai 2500 HD	Cuchara con cepillo 2500 HD
Tav. 3	Benna raccolta con spazzola (version STD)	Bucket with brush (version STD)	Godet avec balai (STD version)	Cuchara con cepillo (versión STD)
Tav. 4	Impianto acqua a pressione	Pressure sprinkling system	Système d'arrosage sous pression	Instalación de riego bajo presión
Tav. 5	Impianto acqua a caduta	Gravity sprinkling system	Système d'arrosage par gravité	Instalación de riego por gravedad
Tav. 6	Spazzola laterale	Side brush	Balai latéral	Cepillo lateral
Tav. 7	Ruote (Optional)	Wheels (Optional)	Roues (Optional)	Ruedas (Optional)



BENNA DI RACCOLTA CON SPAZZOLA (VERSIONE HD)
 BUCKET WITH BRUSH (HD VERSION)
 GODET AVEC BALAI (VERSION HD)
 CUCHARA CON CEPILLO (VERSION HD)

Spazzatrice "Manta"
 Sweeper "Manta"
 Balayeuse "Manta"
 Barredora "Manta"

TAV. 1.0

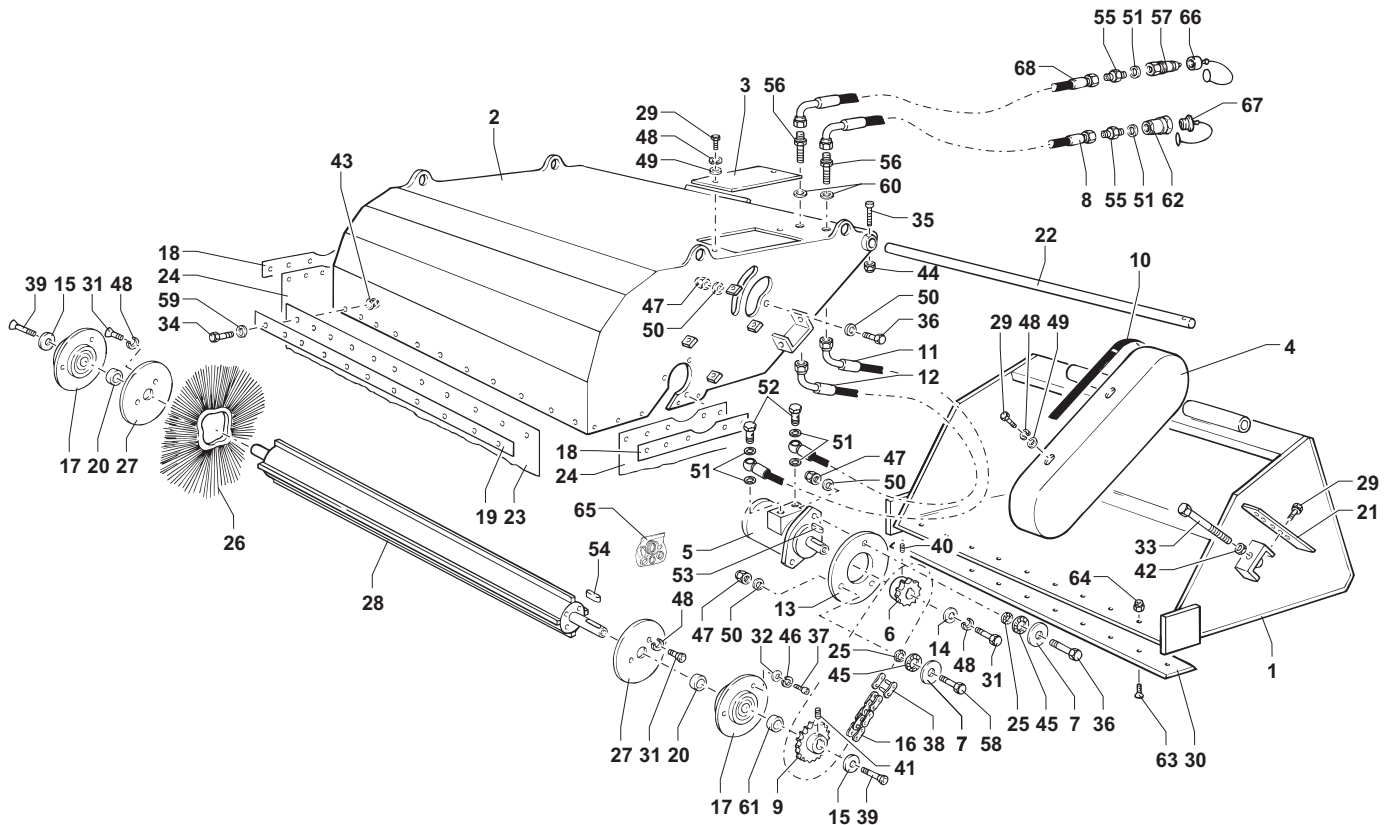

Rif.	CODICE	Descrizione	Description	Designation	Denominaciones	NOTE
1	310000000000	BENNA RACCOLTA MANTA 1100	BUCKET	BENNE	CUCIARA	
1	3100000000100	BENNA RACCOLTA MANTA 1250	BUCKET	BENNE	CUCIARA	
1	3100000000200	BENNA RACCOLTA MANTA 1400	BUCKET	BENNE	CUCIARA	
1	3100000000300	BENNA RACCOLTA MANTA 1550	BUCKET	BENNE	CUCIARA	
1	3100000000600	BENNA RACCOLTA MANTA 1680	BUCKET	BENNE	CUCIARA	
1	3100000000400	BENNA RACCOLTA MANTA 1800	BUCKET	BENNE	CUCIARA	
1	3100000000500	BENNA RACCOLTA MANTA 2100	BUCKET	BENNE	CUCIARA	
2	3101000000000	CARTER MANTA 1100	PROTECTION CASING	CARTER	CÁRTER	
2	3101000000100	CARTER MANTA 1250	PROTECTION CASING	CARTER	CÁRTER	
2	3101000000200	CARTER MANTA 1400	PROTECTION CASING	CARTER	CÁRTER	
2	3101000000300	CARTER MANTA 1550	PROTECTION CASING	CARTER	CÁRTER	
2	3101000000700	CARTER MANTA 1680	PROTECTION CASING	CARTER	CÁRTER	
2	3101000000400	CARTER MANTA 1800	PROTECTION CASING	CARTER	CÁRTER	
2	3101000000500	CARTER MANTA 2100	PROTECTION CASING	CARTER	CÁRTER	
3	7000010020000	COPERCHIO	COVER	COUVERCLE	TAPA	
4	3103000000000	CARTER TRASMISSIONE	TRANSMISSION CASING	CARTER	CÁRTER	
5	4171016000000	MOTORE IDR. MANTA 1100-1680	HYDRAULIC MOTOR	MOTEUR HYDRAULIQUE	MOTOR HIDRÁULICO	
5	4171020000000	MOTORE IDR. MANTA 1800-2100	HYDRAULIC MOTOR	MOTEUR HYDRAULIQUE	MOTOR HIDRÁULICO	
6	6025010340006	PIGNONE Z=12 DA 3/4"	PINION	PIGNON	PINON	
7	6016120050116	RONDELLA	WASHER	RONDELLE	ARANDELA	
8	5242480481903	TUBO FLESSIBILE	FLEXIBLE HOSE	TUYAU FLEXIBLE	TUBO FLEXIBLE	
9	6025010340106	PIGNONE Z=17 DA 3/4"	PINION	PIGNON	PINON	
10	4254000000000	GUAINA CARTER TRASMISS.	SHEATH	GAINÉ	SCHUTZHÜLZE	
11	5246482480653	TUBO FLESSIBILE	FLEXIBLE HOSE	TUYAU FLEXIBLE	TUBO FLEXIBLE	
12	5246482480503	TUBO FLESSIBILE	FLEXIBLE HOSE	TUYAU FLEXIBLE	TUBO FLEXIBLE	
13	7000010080600	FLANGIA	FLANGE	BRIDE	BRIDA	
14	6016080050016	RONDELLA	WASHER	RONDELLE	ARANDELA	
15	6016110050016	RONDELLA	WASHER	RONDELLE	ARANDELA	
16	4191340250099	CATENA 1100 - 1800	CHAIN	CHAÎNE	CADENA	
16	4191340250199	CATENA 2100	CHAIN	CHAÎNE	CADENA	
17	4070035000000	CUSCINETTO	BEARING	PALIER	COJINETE	
18	7000010050600	PIATTO FERMA GOMMA	PLATE	PLATEAU	PLATO	
19	7000010050500	FERMAGOMMA MANTA 1100	PLATE	PLATEAU	PLATO	
19	7000010050400	FERMAGOMMA MANTA 1250	PLATE	PLATEAU	PLATO	

Spazzatrice "Manta"

TAV. 1.0



BENNA DI RACCOLTA CON SPAZZOLA (VERSIONE HD)
BUCKET WITH BRUSH (HD VERSION)
GODET AVEC BALAI (VERSION HD)
CUCHARA CON CEPILLO (VERSION HD)

Spazzatrice "Manta"
Sweeper "Manta"
Balayeuse "Manta"
Barredora "Manta"

TAV. 1.0

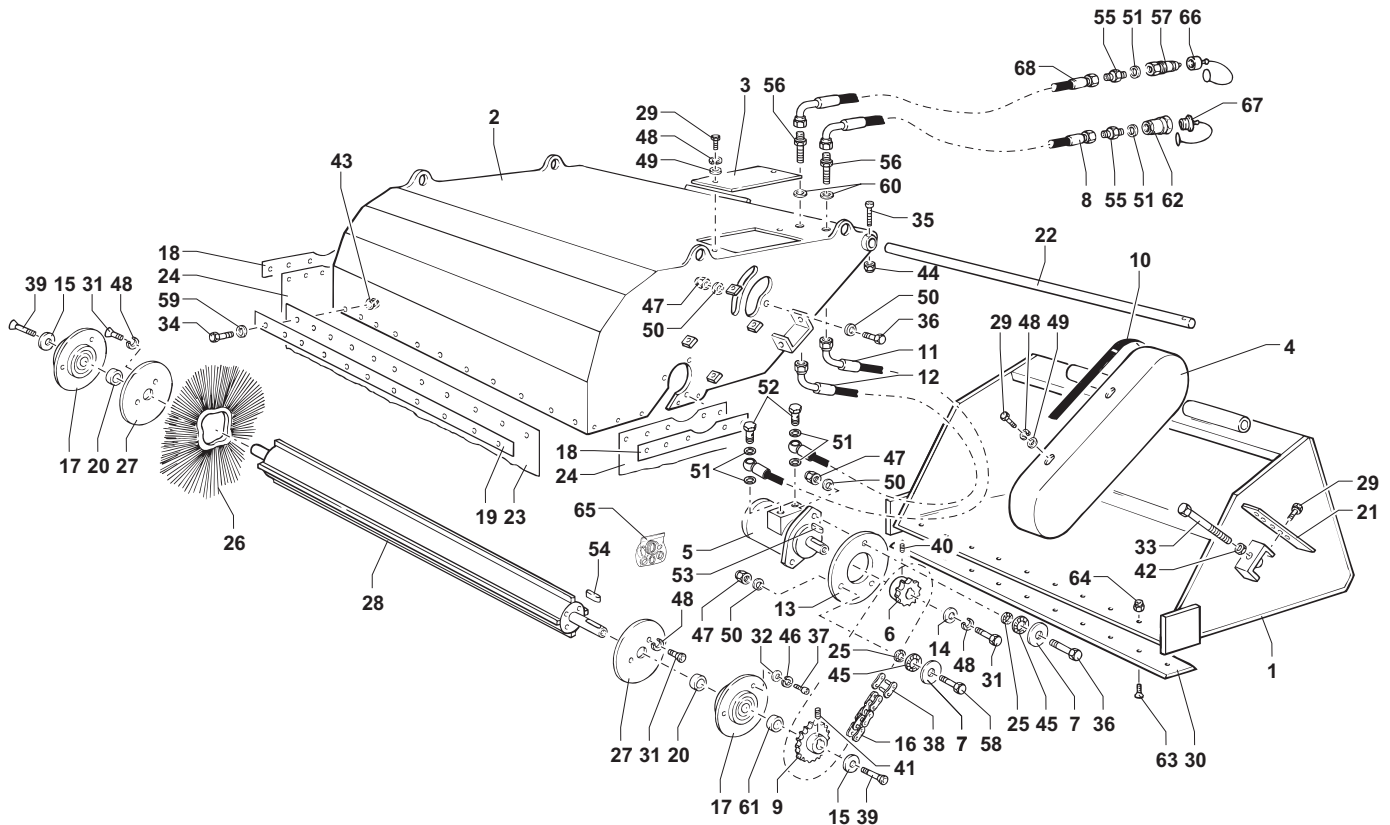

Rif.	CODICE	Descrizione	Description	Designation	Denominaciones	NOTE
19	7000010050300	FERMAGOMMA MANTA 1400	PLATE	PLATEAU	PLATO	
19	7000010050000	FERMAGOMMA MANTA 1550	PLATE	PLATEAU	PLATO	
19	70000A0051500	FERMAGOMMA MANTA 1680	PLATE	PLATEAU	PLATO	
19	7000010050100	FERMA GOMMA MANTA 1800	PLATE	PLATEAU	PLATO	
19	7000010050200	FERMA GOMMA MANTA 2100	PLATE	PLATEAU	PLATO	
20	6016360330000	DISTANZIALE	SPACER	ENTRETOISE	SEPARADOR	12/2004
20	6016360370100	DISTANZIALE	SPACER	ENTRETOISE	SEPARADOR	01/2005
21	7000050083304	PIASTRINA DI SICUREZZA	PLATE	PLAQUETTE	PLACA	
22	610325B250003	PERNO MANTA 1100	PIN	PIVOT	PERNO	
22	610325C750003	PERNO MANTA 1250	PIN	PIVOT	PERNO	
22	610325E250003	PERNO MANTA 1400	PIN	PIVOT	PERNO	
22	610325F750003	PERNO MANTA 1550	PIN	PIVOT	PERNO	
22	610325M250003	PERNO MANTA 1680	PIN	PIVOT	PERNO	
22	610325I250003	PERNO MANTA 1800	PIN	PIVOT	PERNO	
22	610325L250003	PERNO MANTA 2100	PIN	PIVOT	PERNO	
23	7021005000043	GOMMA MANTA 1100	RUBBER	CAOUTCHOUC	GOMA	
23	7021005000143	GOMMA MANTA 1250	RUBBER	CAOUTCHOUC	GOMA	
23	7021005000243	GOMMA MANTA 1400	RUBBER	CAOUTCHOUC	GOMA	
23	7021005000343	GOMMA MANTA 1550	RUBBER	CAOUTCHOUC	GOMA	
23	7021005001543	GOMMA MANTA 1680	RUBBER	CAOUTCHOUC	GOMA	
23	7021005000443	GOMMA MANTA 1800	RUBBER	CAOUTCHOUC	GOMA	
23	7021005000543	GOMMA MANTA 2100	RUBBER	CAOUTCHOUC	GOMA	
24	7021005000643	GOMMA	RUBBER	CAOUTCHOUC	GOMA	
25	4033012020235	RONDELLA DENTELLATA	WASHER	RONDELLE	ARANDELA	
26	4255000000030	SPAZZOLA SETOLE ACCIAIO	BRUSH	BALAI	CEPILLO	
26	4255000000040	SPAZZOLA SETOLE POLIPROPILENE	BRUSH	BALAI	CEPILLO	
27	7000010062600	FLANGIA	FLANGE	BRIDE	BRIDA	
28	3104110000000	ALBERO MANTA 1100	SHAFT	ARBRE	ARBOL	
28	3104125000000	ALBERO MANTA 1250	SHAFT	ARBRE	ARBOL	
28	3104140000000	ALBERO MANTA 1400	SHAFT	ARBRE	ARBOL	
28	3104155000000	ALBERO MANTA 1550	SHAFT	ARBRE	ARBOL	
28	3104168000000	ALBERO MANTA 1680	SHAFT	ARBRE	ARBOL	
28	3104180000000	ALBERO MANTA 1800	SHAFT	ARBRE	ARBOL	
28	3104210000000	ALBERO MANTA 2100	SHAFT	ARBRE	ARBOL	

Spazzatrice "Manta"

TAV. 1.0



BENNA DI RACCOLTA CON SPAZZOLA (VERSIONE HD)
 BUCKET WITH BRUSH (HD VERSION)
 GODET AVEC BALAI (VERSION HD)
 CUCHARA CON CEPILLO (VERSIÓN HD)

Spazzatrice "Manta"
 Sweeper "Manta"
 Balayeuse "Manta"
 Barredora "Manta"

TAV. 1.0

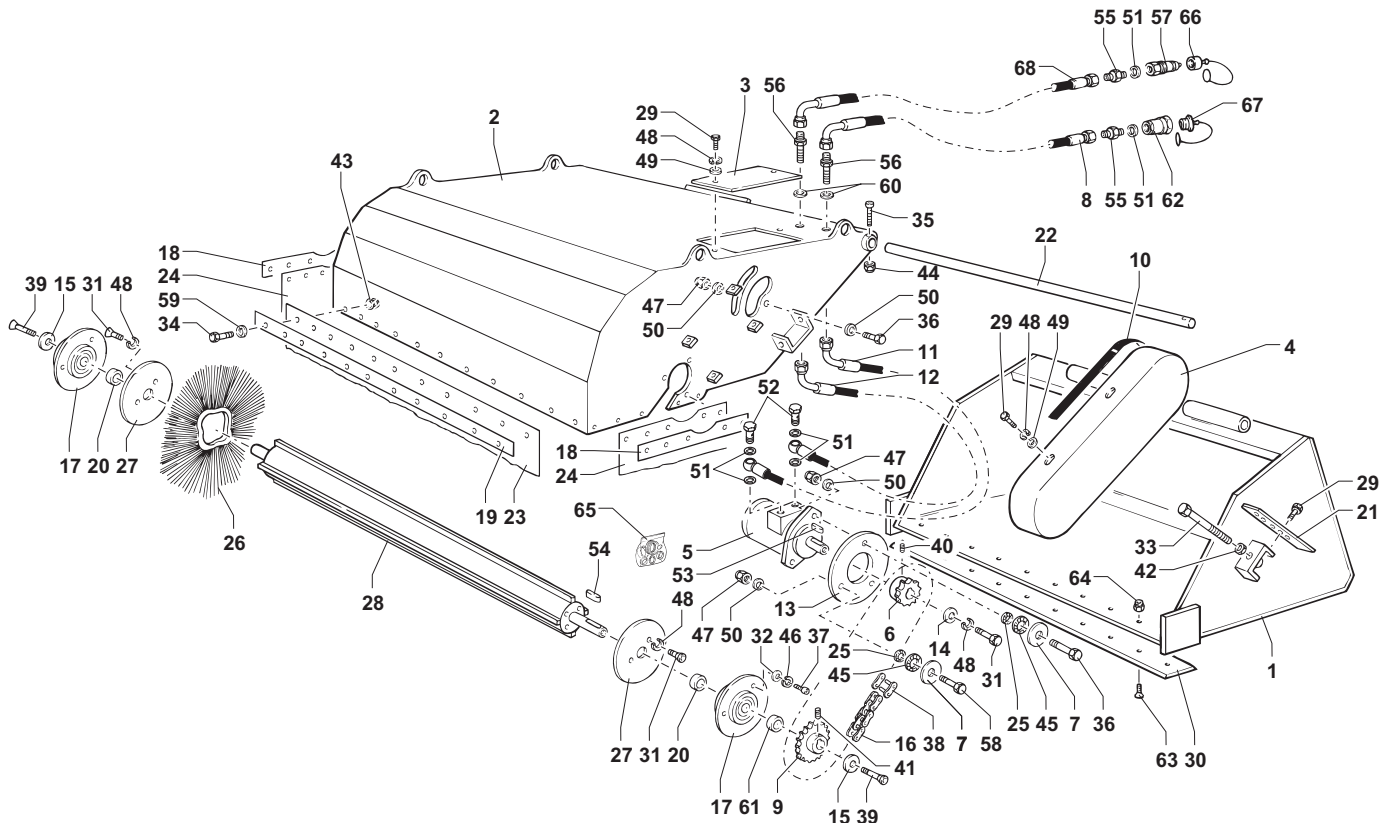

Rif.	CODICE	Descrizione	Description	Designation	Denominaciones	NOTE
29	4003008016210	VITE	SCREW	VIS	TORNILLO	
30	7160161520818	LAMA BENNA MANTA 1100	BLADE	LAME	HOJA	fino a matr. 2247
30	7160161520918	LAMA BENNA MANTA 1250	BLADE	LAME	HOJA	fino a matr. 2247
30	7160161521018	LAMA BENNA MANTA 1400	BLADE	LAME	HOJA	fino a matr. 2247
30	7160161521118	LAMA BENNA MANTA 1550	BLADE	LAME	HOJA	fino a matr. 2247
30	7160161521218	LAMA BENNA MANTA 1800	BLADE	LAME	HOJA	fino a matr. 2247
30	7160161521318	LAMA BENNA MANTA 2100	BLADE	LAME	HOJA	fino a matr. 2247
30	7160161522318	LAMA BENNA MANTA 1100	BLADE	LAME	HOJA	da matr. 2248
30	7160161522418	LAMA BENNA MANTA 1250	BLADE	LAME	HOJA	da matr. 2248
30	7160161522518	LAMA BENNA MANTA 1400	BLADE	LAME	HOJA	da matr. 2248
30	7160161522618	LAMA BENNA MANTA 1550	BLADE	LAME	HOJA	da matr. 2248
30	7160161523219	LAMA BENNA MANTA 1680	BLADE	LAME	HOJA	da matr. 2248
30	7160161522718	LAMA BENNA MANTA 1800	BLADE	LAME	HOJA	da matr. 2248
30	7160161522818	LAMA BENNA MANTA 2100	BLADE	LAME	HOJA	da matr. 2248
31	4003008025210	VITE	SCREW	VIS	TORNILLO	
32	4030010000205	RONDELLA PIANA	WASHER	RONDELLE	ARANDELA	
33	4003024150210	VITE	SCREW	VIS	TORNILLO	fino a matr. 2349
33	4003020150210	VITE	SCREW	VIS	TORNILLO	da matr. 2350
34	4001006025210	VITE	SCREW	VIS	TORNILLO	
35	4005008050210	VITE	SCREW	VIS	TORNILLO	
36	4001012050210	VITE	SCREW	VIS	TORNILLO	
37	4005010030210	VITE	SCREW	VIS	TORNILLO	
38	4192340010099	GIUNTO 1100 - 1800	JOINT	JOINT	JUNTA	
38	4192340010199	GIUNTO 2100	JOINT	JOINT	JUNTA	
39	4006010016210	VITE	SCREW	VIS	TORNILLO	
40	4025006008020	GRANO	SCREW	VIS	TORNILLO	
41	4025008020020	GRANO	SCREW	VIS	TORNILLO	
42	4012024000205	DADO MEDIO	NUT	ECROU	TUERCA	fino a matr. 2349
42	4012020000205	DADO MEDIO	NUT	ECROU	TUERCA	da matr. 2350
43	4016006000205	DADO AUTOBLOCCANTE	SELF-LOCKING NUT	ECROU DE SURETE	TUERCA AUTOTRABADORA	
44	4016008000205	DADO AUTOBLOCCANTE	SELF-LOCKING NUT	ECROU DE SURETE	TUERCA AUTOTRABADORA	
45	4033020033235	RONDELLA DENTELLATA	WASHER	RONDELLE	ARANDELA	
46	4032010000235	RONDELLA GROWER	SPRING WASHER	RONDELLE ÉLASTIQUE	ARANDELA ELÁSTICA	
47	4016012000205	DADO AUTOBLOCCANTE	SELF-LOCKING NUT	ECROU DE SURETE	TUERCA AUTOTRABADORA	

Spazzatrice "Manta"

TAV. 1.0



BENNA DI RACCOLTA CON SPAZZOLA (VERSIONE HD)
 BUCKET WITH BRUSH (HD VERSION)
 GODET AVEC BALAI (VERSION HD)
 CUCHARA CON CEPILLO (VERSIÓN HD)

Spazzatrice "Manta"
 Sweeper "Manta"
 Balayeuse "Manta"
 Barredora "Manta"

TAV. 1.0

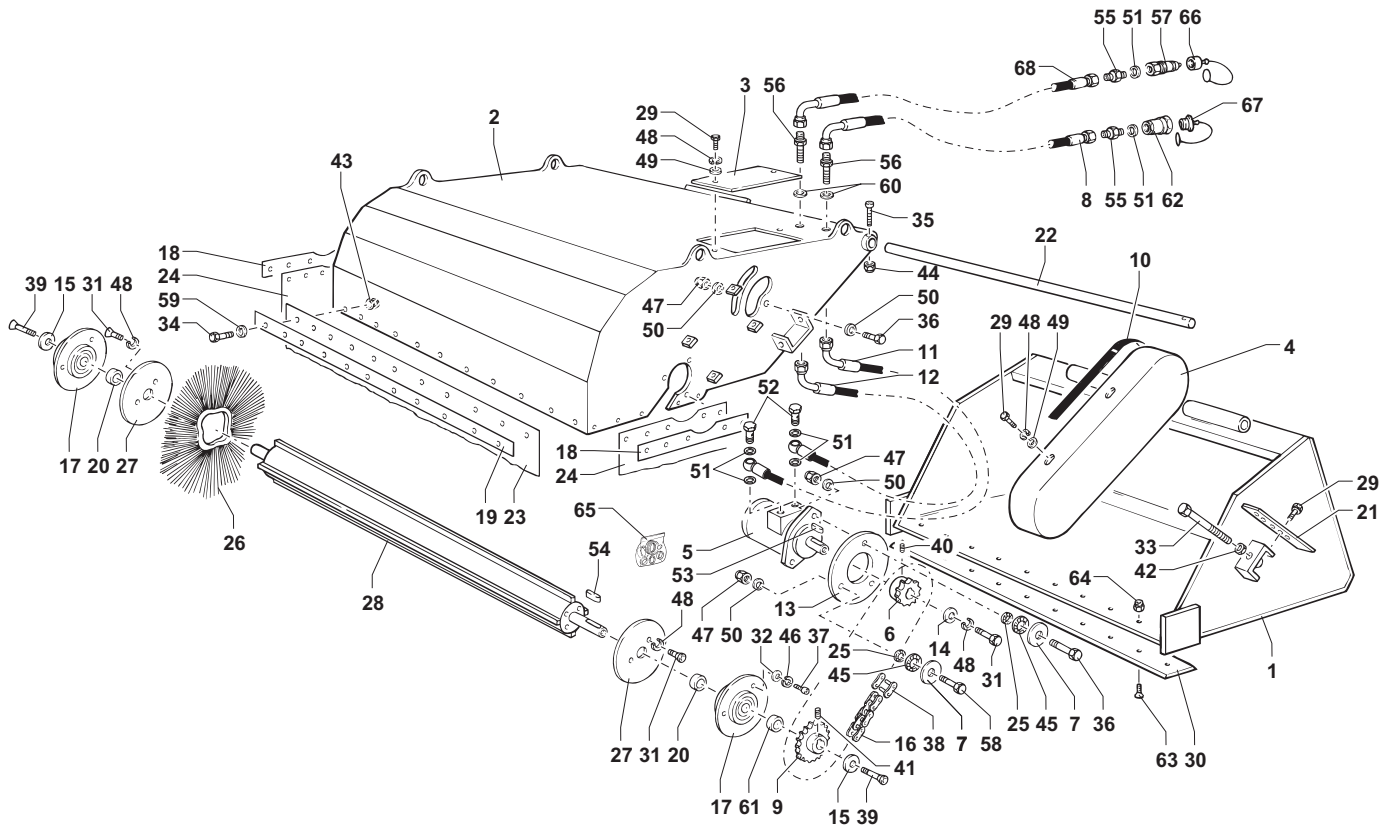

Rif.	CODICE	Descrizione	Description	Designation	Denominaciones	NOTE
48	4032008000235	RONDELLA GROWER	SPRING WASHER	RONDELLE ÉLASTIQUE	ARANDELA ELÁSTICA	
49	4030008000205	RONDELLA PIANA	WASHER	RONDELLE	ARANDELA	
50	4030012000205	RONDELLA PIANA	WASHER	RONDELLE	ARANDELA	
51	4120000012000	RONDELLA DI TENUTA	WASHER	RONDELLE	ARANDELA	
51	4120000034000	RONDELLA DI TENUTA	WASHER	RONDELLE	ARANDELA	HIGH FLOW
52	4207011001200	VITE	SCREW	VIS	TORNILLO	
53	4043080703002	CHIAVETTA	KEY	CLAVETTE	CHAVETA	
54	4043100804002	CHIAVETTA	KEY	CLAVETTE	CHAVETA	
55	4206012005310	RACCORDO	PIPE FITTING	RACCORD DE TUAYU	CONEXIÓN	
55	4206002000800	RACCORDO	PIPE FITTING	RACCORD DE TUAYU	CONEXIÓN	HIGH FLOW
56	4206012000000	PASSAPARETE	THROUGH COUPLING	RACCORD PASSANT	ACOPLAMIENTO PASANTE	
57	4150000343000	INNESTO RAPIDO M.	MALE QUICK COUPLING	COUPLEUR RAPIDE MÂLE	ENCHUFE RÁPIDO MACHO	
57	4150000305000	INNESTO RAPIDO M.	MALE QUICK COUPLING	COUPLEUR RAPIDE MÂLE	ENCHUFE RÁPIDO MACHO	HIGH FLOW
58	4001012040210	VITE	SCREW	VIS	TORNILLO	
59	4028006018205	RONDELLA PIANA	WASHER	RONDELLE	ARANDELA	
60	4030020000205	RONDELLA PIANA	WASHER	RONDELLE	ARANDELA	
61	6016350170016	DISTANZIALE	SPACER	ENTRETOISE	SEPARADOR	
62	4150000343100	INNESTO RAPIDO F.	FEMALE QUICK COUPLING	COUPLEUR RAPIDE FEMELLE	ENCHUFE RÁPIDO HEMBRA	
62	4150000345100	INNESTO RAPIDO F.	FEMALE QUICK COUPLING	COUPLEUR RAPIDE FEMELLE	ENCHUFE RÁPIDO HEMBRA	HIGH FLOW
63	4006010035210	VITE	SCREW	VIS	TORNILLO	
64	4016010000205	DADO AUTOBLOCCANTE	SELF-LOCKING NUT	ECROU DE SURETE	TUERCA AUTOTRABADORA	
65	2011000002700	KIT GUARNIZIONI MOTORE IDR.	JOINT KIT	KIT DE JOINT	KIT JUNTAS	
66	4280100343100	TAPPO FEMMINA	PLUG	BOUCHON	TAPÓN	
66	4280100345100	TAPPO FEMMINA	PLUG	BOUCHON	TAPÓN	HIGH FLOW
67	4280100343000	TAPPO MASCHIO	PLUG	BOUCHON	TAPÓN	
67	4280100345000	TAPPO MASCHIO	PLUG	BOUCHON	TAPÓN	HIGH FLOW
68	5242480482003	TUBO FLESSIBILE	FLEXIBLE HOSE	TUYAU FLEXIBLE	TUBO FLEXIBLE	



BENNA DI RACCOLTA CON SPAZZOLA 2500 HD
 BUCKET WITH BRUSH 2500 HD
 GODET AVEC BALAI 2500 HD
 CUCHARA CON CEPILLO 2500 HD

Spazzatrice "Manta"
 Sweeper "Manta"
 Balayeuse "Manta"
 Barredora "Manta"

TAV. 2.0

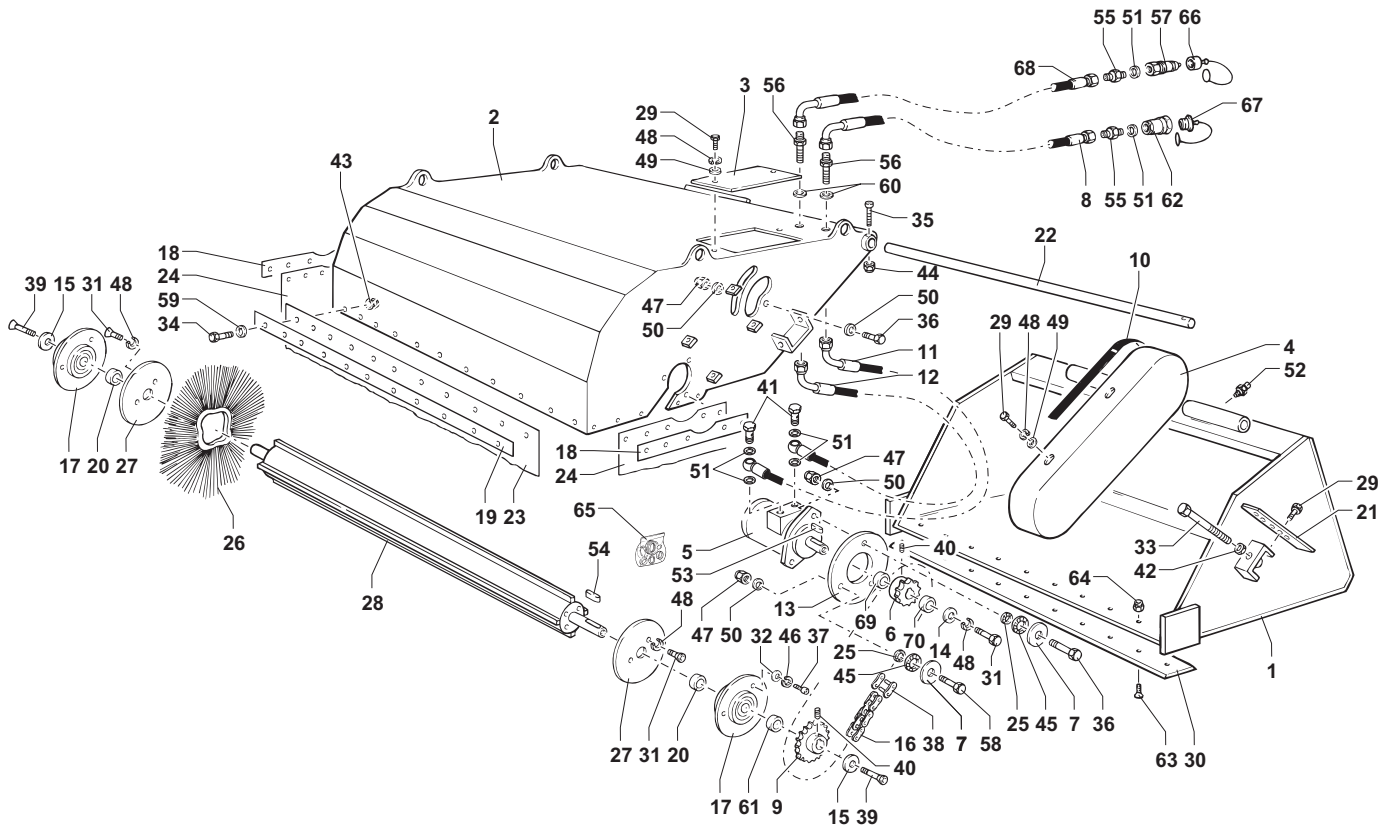

Rif.	CODICE	Descrizione	Description	Designation	Denominaciones	NOTE
1	310000000700	BENNA RACCOLTA MANTA	BUCKET	BENNE	CUCIARA	
2	310100000800	CARTER MANTA	PROTECTION CASING	CARTER	CÁRTER	
3	7000010020000	COPERCHIO	COVER	COUVERCLE	TAPA	
4	3103000000000	CARTER TRASMISSIONE	TRANSMISSION CASING	CARTER	CÁRTER	
5	4171025000102	MOTORE IDR. MANTA	HYDRAULIC MOTOR	MOTEUR HYDRAULIQUE	MOTOR HIDRÁULICO	
6	6025010340999	PIGNONE Z=12 DA 3/4"	PINION	PIGNON	PINON	
7	6016120050116	RONDELLA	WASHER	RONDELLE	ARANDELA	
8	5242480482303	TUBO FLESSIBILE	FLEXIBLE HOSE	TUYAU FLEXIBLE	TUBO FLEXIBLE	
9	6025010341099	PIGNONE Z=17 DA 3/4"	PINION	PIGNON	PINON	
10	4254000000000	GUAINA CARTER TRASMISS.	SHEATH	GAINE	SCHUTZHÜLZE	
11	5246482480653	TUBO FLESSIBILE	FLEXIBLE HOSE	TUYAU FLEXIBLE	TUBO FLEXIBLE	
12	5246482480503	TUBO FLESSIBILE	FLEXIBLE HOSE	TUYAU FLEXIBLE	TUBO FLEXIBLE	
13	7000010080600	FLANGIA	FLANGE	BRIDE	BRIDA	
14	6016080050016	RONDELLA	WASHER	RONDELLE	ARANDELA	
15	6016110050016	RONDELLA	WASHER	RONDELLE	ARANDELA	
16	4191340250199	CATENA	CHAIN	CHAÎNE	CADENA	
17	4070040000000	CUSCINETTO	BEARING	PALIER	COJINETE	
18	7000010050600	PIATTO FERMA GOMMA	PLATE	PLATEAU	PLATO	
19	7000010052700	FERMAGOMMA MANTA	PLATE	PLATEAU	PLATO	
20	6016400390016	DISTANZIALE	SPACER	ENTRETOISE	SEPARADOR	01/2005
21	7000050083304	PIASTRINA DI SICUREZZA	PLATE	PLAQUETTE	PLACA	
22	610330N250003	PERNO MANTA	PIN	PIVOT	PERNO	
23	7021005001643	GOMMA MANTA	RUBBER	CAOUTCHOUC	GOMA	
24	7021005001743	GOMMA	RUBBER	CAOUTCHOUC	GOMA	
25	4033012020235	RONDELLA DENTELLATA	WASHER	RONDELLE	ARANDELA	
26	4255000000030	SPAZZOLA SETOLE ACCIAIO	BRUSH	BALAI	CEPILLO	
26	4255000000040	SPAZZOLA SETOLE POLIPROPILENE	BRUSH	BALAI	CEPILLO	
27	7000010107800	FLANGIA	FLANGE	BRIDE	BRIDA	
28	3104250000000	ALBERO MANTA	SHAFT	ARBRE	ARBOL	
29	4003008016210	VITE	SCREW	VIS	TORNILLO	
30	7160161522218	LAMA BENNA MANTA	BLADE	LAME	HOJA	da matr. 2248
31	4003008025210	VITE	SCREW	VIS	TORNILLO	
32	4030010000205	RONDELLA PIANA	WASHER	RONDELLE	ARANDELA	
33	4003024150210	VITE	SCREW	VIS	TORNILLO	fino a matr. 2349

Spazzatrice "Manta"

TAV. 2.0



BENNA DI RACCOLTA CON SPAZZOLA 2500 HD
 BUCKET WITH BRUSH 2500 HD
 GODET AVEC BALAI 2500 HD
 CUCHARA CON CEPILLO 2500 HD

Spazzatrice "Manta"
 Sweeper "Manta"
 Balayeuse "Manta"
 Barredora "Manta"

TAV. 2.0

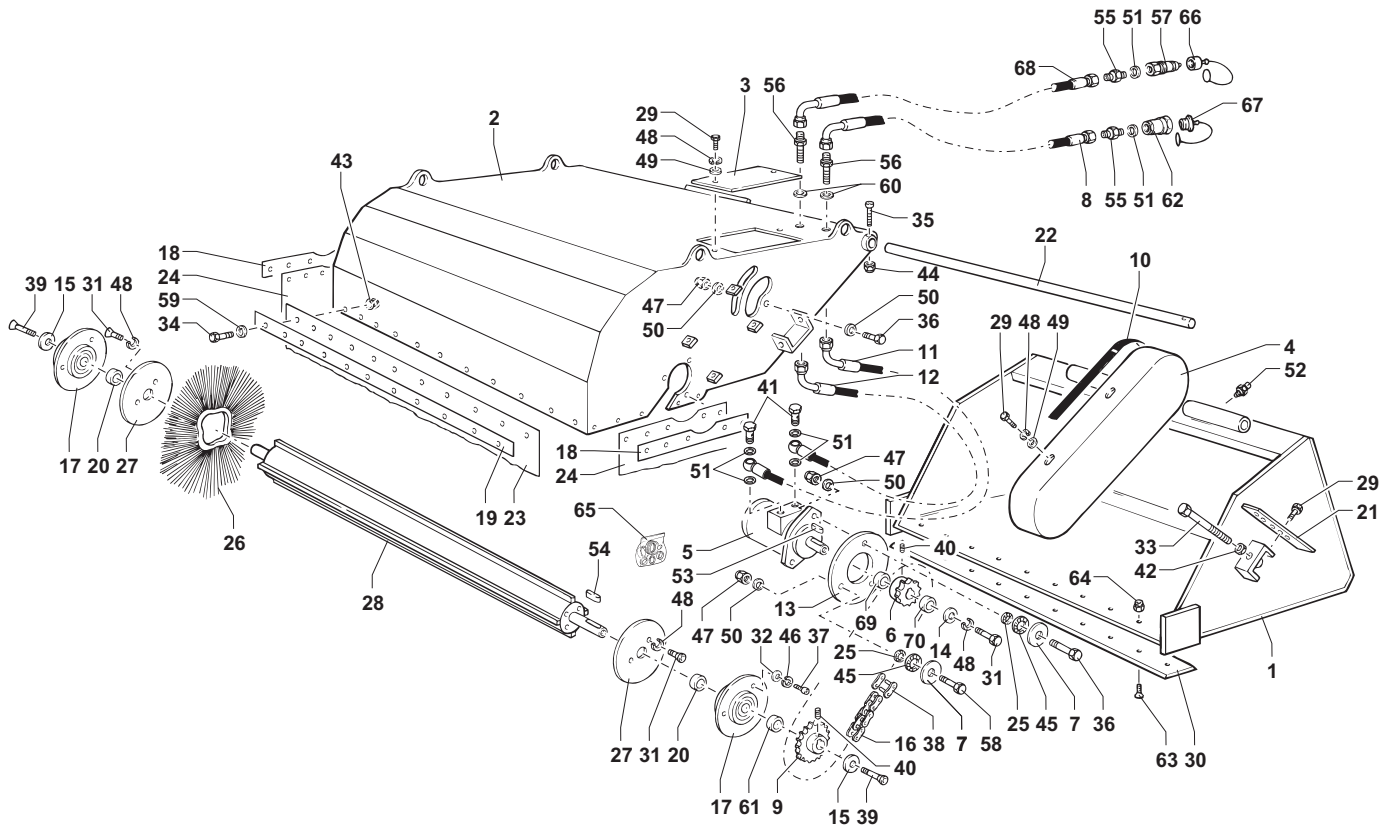

Rif.	CODICE	Descrizione	Description	Designation	Denominaciones	NOTE
33	4003020150210	VITE	SCREW	VIS	TORNILLO	da matr. 2350
34	4001006030210	VITE	SCREW	VIS	TORNILLO	
35	4005008050210	VITE	SCREW	VIS	TORNILLO	
36	4001012060210	VITE	SCREW	VIS	TORNILLO	
37	4001012030210	VITE	SCREW	VIS	TORNILLO	
38	4192340010199	GIUNTO	JOINT	JUNTA	JUNTA	
39	4006010016210	VITE	SCREW	VIS	TORNILLO	
40	4025008020020	GRANO	SCREW	VIS	TORNILLO	
41	4207011001200	VITE	SCREW	VIS	TORNILLO	
42	4012024000205	DADO MEDIO	NUT	ECROU	TUERCA	fino a matr. 2349
42	4012020000205	DADO MEDIO	NUT	ECROU	TUERCA	da matr. 2350
43	4016006000205	DADO AUTOBLOCCANTE	SELF-LOCKING NUT	ECROU DE SURETE	TUERCA AUTOTRABADORA	
44	4016008000205	DADO AUTOBLOCCANTE	SELF-LOCKING NUT	ECROU DE SURETE	TUERCA AUTOTRABADORA	
45	4033020033235	RONDELLA DENTELLATA	WASHER	RONDELLE	ARANDELA	
46	4032012000235	RONDELLA GROWER	SPRING WASHER	RONDELLE ÉLASTIQUE	ARANDELA ELÁSTICA	
47	4016012000205	DADO AUTOBLOCCANTE	SELF-LOCKING NUT	ECROU DE SURETE	TUERCA AUTOTRABADORA	
48	4032008000235	RONDELLA GROWER	SPRING WASHER	RONDELLE ÉLASTIQUE	ARANDELA ELÁSTICA	
49	4030008000205	RONDELLA PIANA	WASHER	RONDELLE	ARANDELA	
50	4030012000205	RONDELLA PIANA	WASHER	RONDELLE	ARANDELA	
51	4120000012000	RONDELLA DI TENUTA	WASHER	RONDELLE	ARANDELA	
51	4120000034000	RONDELLA DI TENUTA	WASHER	RONDELLE	ARANDELA	HIGH FLOW
52	4041006000231	INGRASSATORE DIRITTO	GREASE NIPPLE	GRAISSEUR	ENGRASADOR	
53	4043080703002	CHIAVETTA	KEY	CLAVETTE	CHAVETA	
54	4043100804002	CHIAVETTA	KEY	CLAVETTE	CHAVETA	
55	4206012005310	RACCORDO	PIPE FITTING	RACCORD DE TUAYU	CONEXIÓN	
55	4206002000800	RACCORDO	PIPE FITTING	RACCORD DE TUAYU	CONEXIÓN	HIGH FLOW
56	4206012000000	PASSAPARETE	THROUGH COUPLING	RACCORD PASSANT	ACOPLIAMIENTO PASANTE	
57	4150000343000	INNESTO RAPIDO M.	MALE QUICK COUPLING	COUPLEUR RAPIDE MÂLE	ENCHUFE RÁPIDO MACHO	
57	4150000305000	INNESTO RAPIDO M.	MALE QUICK COUPLING	COUPLEUR RAPIDE MÂLE	ENCHUFE RÁPIDO MACHO	HIGH FLOW
58	4001012045210	VITE	SCREW	VIS	TORNILLO	
59	4028006018205	RONDELLA PIANA	WASHER	RONDELLE	ARANDELA	
60	4030020000205	RONDELLA PIANA	WASHER	RONDELLE	ARANDELA	
61	6016400150516	DISTANZIALE	SPACER	ENTRETOISE	SEPARADOR	
62	4150000343100	INNESTO RAPIDO F.	FEMALE QUICK COUPLING	COUPLEUR RAPIDE FEMELLE	ENCHUFE RÁPIDO HEMBRA	



BENNA DI RACCOLTA CON SPAZZOLA (VERSIONE STD)
 BUCKET WITH BRUSH (STD VERSION)
 GODET AVEC BALAI (VERSION STD)
 CUCHARA CON CEPILLO (VERSION STD)

Spazzatrice "Manta"
 Sweeper "Manta"
 Balayeuse "Manta"
 Barredora "Manta"

TAV. 3.0

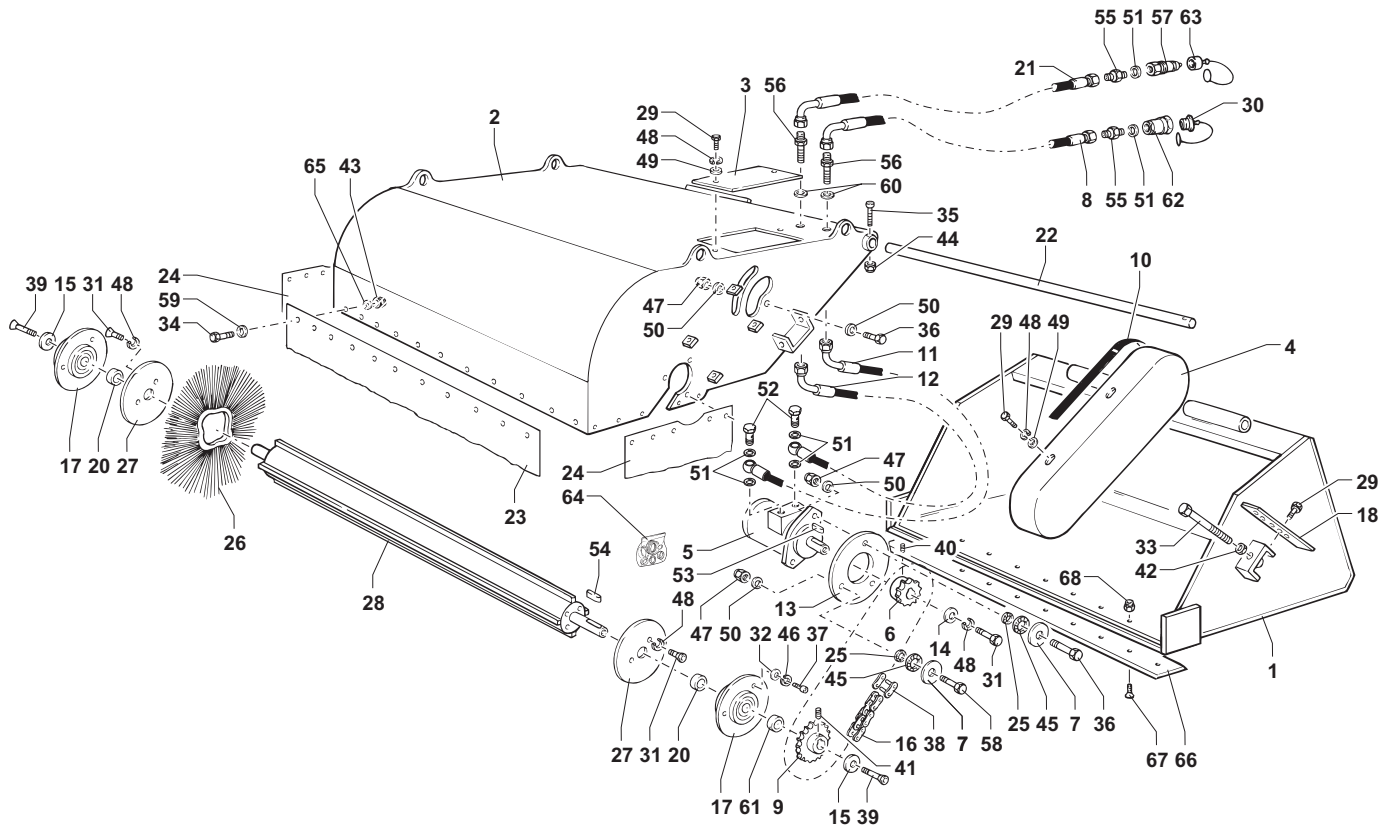

Rif.	CODICE	Descrizione	Description	Designation	Denominaciones	NOTE
1	311000000100	BENNA RACCOLTA MANTA 1250	BUCKET	BENNE	CUCIARA	
1	311000000200	BENNA RACCOLTA MANTA 1400	BUCKET	BENNE	CUCIARA	
1	311000000300	BENNA RACCOLTA MANTA 1550	BUCKET	BENNE	CUCIARA	
1	311000000600	BENNA RACCOLTA MANTA 1680	BUCKET	BENNE	CUCIARA	
1	311000000400	BENNA RACCOLTA MANTA 1800	BUCKET	BENNE	CUCIARA	
2	310900000100	CARTER MANTA 1250	PROTECTION CASING	CARTER	CÁRTER	
2	310900000200	CARTER MANTA 1400	PROTECTION CASING	CARTER	CÁRTER	
2	310900000300	CARTER MANTA 1550	PROTECTION CASING	CARTER	CÁRTER	
2	310900000600	CARTER MANTA 1680	PROTECTION CASING	CARTER	CÁRTER	
2	310900000400	CARTER MANTA 1800	PROTECTION CASING	CARTER	CÁRTER	
3	7000010020000	COPERCHIO	COVER	COUVERCLE	TAPA	
4	3103000000000	CARTER TRASMISSIONE	TRANSMISSION CASING	CARTER	CÁRTER	
5	4171016000000	MOT. IDR. MANTA 1250-1680	HYDRAULIC MOTOR	MOTEUR HYDRAULIQUE	MOTOR HIDRÁULICO	
5	4171020000000	MOT. IDR. MANTA 1800	HYDRAULIC MOTOR	MOTEUR HYDRAULIQUE	MOTOR HIDRÁULICO	
6	6025010340006	PIGNONE Z=12 DA 3/4"	PINION	PIGNON	PINON	
7	6016120050116	RONDELLA	WASHER	RONDELLE	ARANDELA	
8	5242480481903	TUBO FLESSIBILE	FLEXIBLE HOSE	TUYAU FLEXIBLE	TUBO FLEXIBLE	
9	6025010340106	PIGNONE Z=17 DA 3/4"	PINION	PIGNON	PINON	
10	4254000000000	GUAINA CARTER TRASMISS.	SHEATH	GAINÉ	SCHUTZHÜLZE	
11	5246482480653	TUBO FLESSIBILE	FLEXIBLE HOSE	TUYAU FLEXIBLE	TUBO FLEXIBLE	
12	5246482480503	TUBO FLESSIBILE	FLEXIBLE HOSE	TUYAU FLEXIBLE	TUBO FLEXIBLE	
13	7000010080600	FLANGIA	FLANGE	BRIDE	BRIDA	
14	6016080050016	RONDELLA	WASHER	RONDELLE	ARANDELA	
15	6016110050016	RONDELLA	WASHER	RONDELLE	ARANDELA	
16	4191340250099	CATENA	CHAIN	CHAÎNE	CADENA	
17	4070035000000	CUSCINETTO	BEARING	PALIER	COJINETE	
18	7000050083304	PIASTRINA DI SICUREZZA	PLATE	PLAQUETTE	PLACA	
20	6016360370100	DISTANZIALE	SPACER	ENTRETOISE	SEPARADOR	
21	5242480482003	TUBO FLESSIBILE	FLEXIBLE HOSE	TUYAU FLEXIBLE	TUBO FLEXIBLE	
22	610325C750003	PERNO MANTA 1250	PIN	PIVOT	PERNO	
22	610325E250003	PERNO MANTA 1400	PIN	PIVOT	PERNO	
22	610325F750003	PERNO MANTA 1550	PIN	PIVOT	PERNO	
22	610325M250003	PERNO MANTA 1680	PIN	PIVOT	PERNO	
22	610325I250003	PERNO MANTA 1800	PIN	PIVOT	PERNO	



BENNA DI RACCOLTA CON SPAZZOLA (VERSIONE STD)
 BUCKET WITH BRUSH (STD VERSION)
 GODET AVEC BALAI (VERSION STD)
 CUCHARA CON CEPILLO (VERSION STD)

Spazzatrice "Manta"
 Sweeper "Manta"
 Balayeuse "Manta"
 Barredora "Manta"

TAV. 3.0

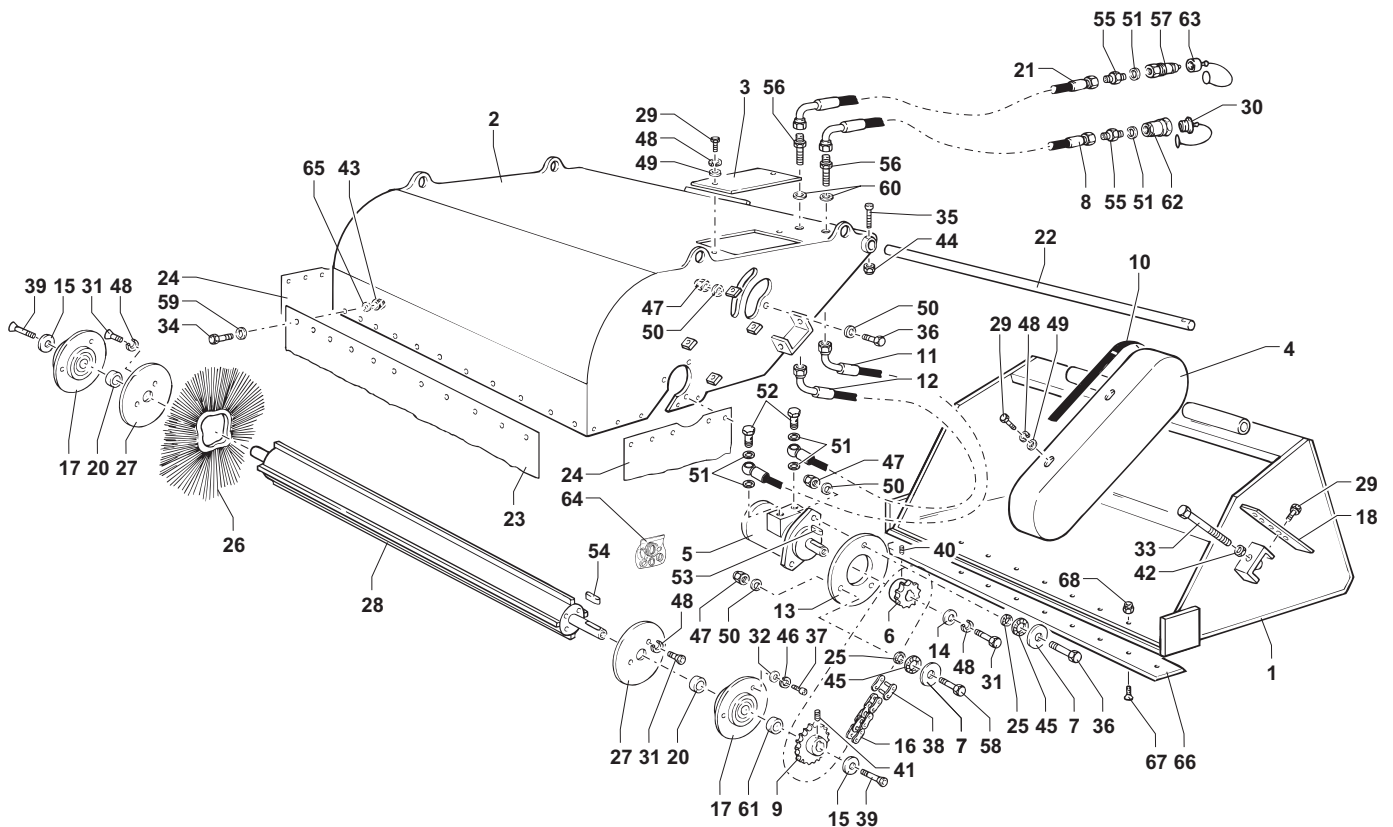

Rif.	CODICE	Descrizione	Description	Designation	Denominaciones	NOTE
23	7021005001843	GOMMA MANTA 1250	RUBBER	CAOUTCHOUC	GOMA	
23	7021005001943	GOMMA MANTA 1400	RUBBER	CAOUTCHOUC	GOMA	
23	7021005002043	GOMMA MANTA 1550	RUBBER	CAOUTCHOUC	GOMA	
23	7021005001443	GOMMA MANTA 1680	RUBBER	CAOUTCHOUC	GOMA	
23	7021005002143	GOMMA MANTA 1800	RUBBER	CAOUTCHOUC	GOMA	
24	7021005002243	GOMMA	RUBBER	CAOUTCHOUC	GOMA	
25	4033012020235	RONDELLA DENTELLATA	WASHER	RONDELLE	ARANDELA	
26	4255000000030	SPAZZOLA SETOLE ACCIAIO	BRUSH	BALAI	CEPILLO	
26	4255000000040	SPAZZOLA SETOLE POLIPROPILENE	BRUSH	BALAI	CEPILLO	
27	7000010062600	FLANGIA	FLANGE	BRIDE	BRIDA	
28	3104125000000	ALBERO MANTA 1250	SHAFT	ARBRE	ARBOL	
28	3104140000000	ALBERO MANTA 1400	SHAFT	ARBRE	ARBOL	
28	3104155000000	ALBERO MANTA 1550	SHAFT	ARBRE	ARBOL	
28	3104168000000	ALBERO MANTA 1680	SHAFT	ARBRE	ARBOL	
28	3104180000000	ALBERO MANTA 1800	SHAFT	ARBRE	ARBOL	
29	4003008016210	VITE	SCREW	VIS	TORNILLO	
30	4280100343000	TAPPO MASCHIO	PLUG	BOUCHON	TAPÓN	
30	4280100345000	TAPPO MASCHIO	PLUG	BOUCHON	TAPÓN	HIGH FLOW
31	4003008025210	VITE	SCREW	VIS	TORNILLO	
32	4030010000205	RONDELLA PIANA	WASHER	RONDELLE	ARANDELA	
33	4003020150210	VITE	SCREW	VIS	TORNILLO	
34	4001006025210	VITE	SCREW	VIS	TORNILLO	
35	4005008050210	VITE	SCREW	VIS	TORNILLO	
36	4001012050210	VITE	SCREW	VIS	TORNILLO	
37	4005010030210	VITE	SCREW	VIS	TORNILLO	
38	4192340010099	GIUNTO	JOINT	JOINT	JUNTA	
39	4006010016210	VITE	SCREW	VIS	TORNILLO	
40	4025006008020	GRANO	SCREW	VIS	TORNILLO	
41	4025008020020	GRANO	SCREW	VIS	TORNILLO	
42	4012020000205	DADO MEDIO	NUT	ECROU	TUERCA	
43	4016006000205	DADO AUTOBLOCCANTE	SELF-LOCKING NUT	ECROU DE SURETE	TUERCA AUTOTRABADORA	
44	4016008000205	DADO AUTOBLOCCANTE	SELF-LOCKING NUT	ECROU DE SURETE	TUERCA AUTOTRABADORA	
45	4033020033235	RONDELLA DENTELLATA	WASHER	RONDELLE	ARANDELA	
46	4032010000235	RONDELLA GROWER	SPRING WASHER	RONDELLE ÉLASTIQUE	ARANDELA ELÁSTICA	

Spazzatrice "Manta"

TAV. 3.0



BENNA DI RACCOLTA CON SPAZZOLA (VERSIONE STD)
 BUCKET WITH BRUSH (STD VERSION)
 GODET AVEC BALAI (VERSION STD)
 CUCHARA CON CEPILLO (VERSION STD)

Spazzatrice "Manta"
 Sweeper "Manta"
 Balayeuse "Manta"
 Barredora "Manta"

TAV. 3.0

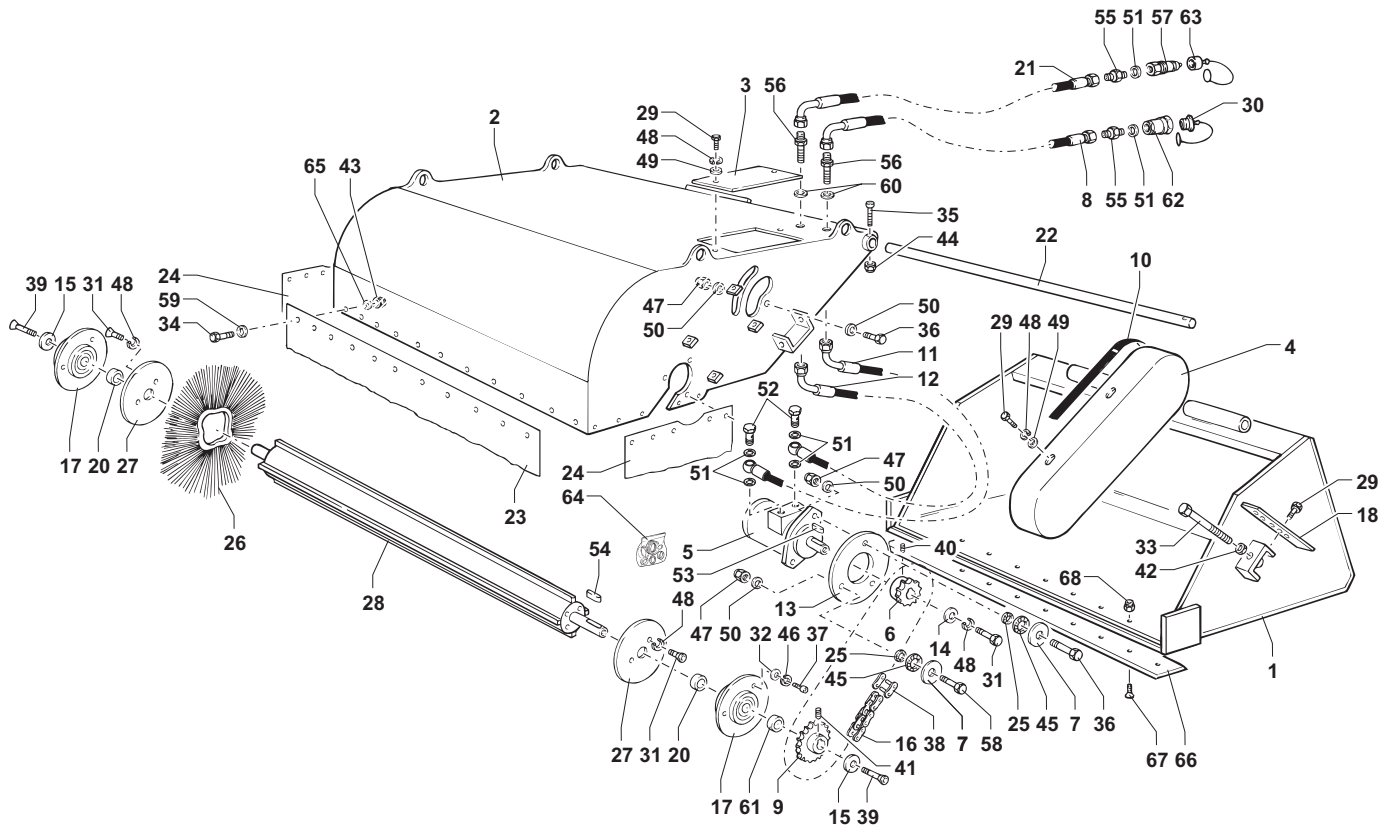

Rif.	CODICE	Descrizione	Description	Designation	Denominaciones	NOTE
47	4016012000205	DADO AUTOBLOCCANTE	SELF-LOCKING NUT	ECROU DE SURETE	TUERCA AUTOTRABADORA	
48	4032008000235	RONDELLA GROWER	SPRING WASHER	RONDELLE ÉLASTIQUE	ARANDELA ELÁSTICA	
49	4030008000205	RONDELLA PIANA	WASHER	RONDELLE	ARANDELA	
50	4030012000205	RONDELLA PIANA	WASHER	RONDELLE	ARANDELA	
51	4120000012000	RONDELLA DI TENUTA	WASHER	RONDELLE	ARANDELA	
51	4120000034000	RONDELLA DI TENUTA	WASHER	RONDELLE	ARANDELA	HIGH FLOW
52	4207011001200	VITE	SCREW	VIS	TORNILLO	
53	4043080703002	CHIAVETTA	KEY	CLAVETTE	CHAVETA	
54	4043100804002	CHIAVETTA	KEY	CLAVETTE	CHAVETA	
55	4206012005310	RACCORDO	PIPE FITTING	RACCORD DE TUAYU	CONEXIÓN	
55	4206002000800	RACCORDO	PIPE FITTING	RACCORD DE TUAYU	CONEXIÓN	HIGH FLOW
56	4206012000000	PASSAPARETE	THROUGH COUPLING	RACCORD PASSANT	ACOPLAMIENTO PASANTE	
57	4150000343000	INNESTO RAPIDO M.	MALE QUICK COUPLING	COUPLEUR RAPIDE MÂLE	ENCHUFE RÁPIDO MACHO	
57	4150000305000	INNESTO RAPIDO M.	MALE QUICK COUPLING	COUPLEUR RAPIDE MÂLE	ENCHUFE RÁPIDO MACHO	HIGH FLOW
58	4001012040210	VITE	SCREW	VIS	TORNILLO	
59	4028006018205	RONDELLA PIANA	WASHER	RONDELLE	ARANDELA	
60	4030020000205	RONDELLA PIANA	WASHER	RONDELLE	ARANDELA	
61	6016350170016	DISTANZIALE	SPACER	ENTRETOISE	SEPARADOR	
62	4150000343100	INNESTO RAPIDO F.	FEMALE QUICK COUPLING	COUPLEUR RAPIDE FEMELLE	ENCHUFE RÁPIDO HEMBRA	
62	4150000345100	INNESTO RAPIDO F.	FEMALE QUICK COUPLING	COUPLEUR RAPIDE FEMELLE	ENCHUFE RÁPIDO HEMBRA	HIGH FLOW
63	4280100343100	TAPPO FEMMINA	PLUG	BOUCHON	TAPÓN	
63	4280100345100	TAPPO FEMMINA	PLUG	BOUCHON	TAPÓN	HIGH FLOW
64	2011000002700	KIT GUARNIZIONI	JOINT KIT	KIT DE JOINT	KIT JUNTAS	
65	4028006024205	RONDELLA PIANA	WASHER	RONDELLE	ARANDELA	
66	7160161104018	LAMA BENNA MANTA 1250	BLADE	LAME	HOJA	
66	7160161103518	LAMA BENNA MANTA 1400	BLADE	LAME	HOJA	
66	7160161103118	LAMA BENNA MANTA 1550	BLADE	LAME	HOJA	
66	7160161103218	LAMA BENNA MANTA 1680	BLADE	LAME	HOJA	
66	7160161103318	LAMA BENNA MANTA 1800	BLADE	LAME	HOJA	
67	4006010035210	VITE	SCREW	VIS	TORNILLO	
68	4016010000205	DADO AUTOBLOCCANTE	SELF-LOCKING NUT	ECROU DE SURETE	TUERCA AUTOTRABADORA	

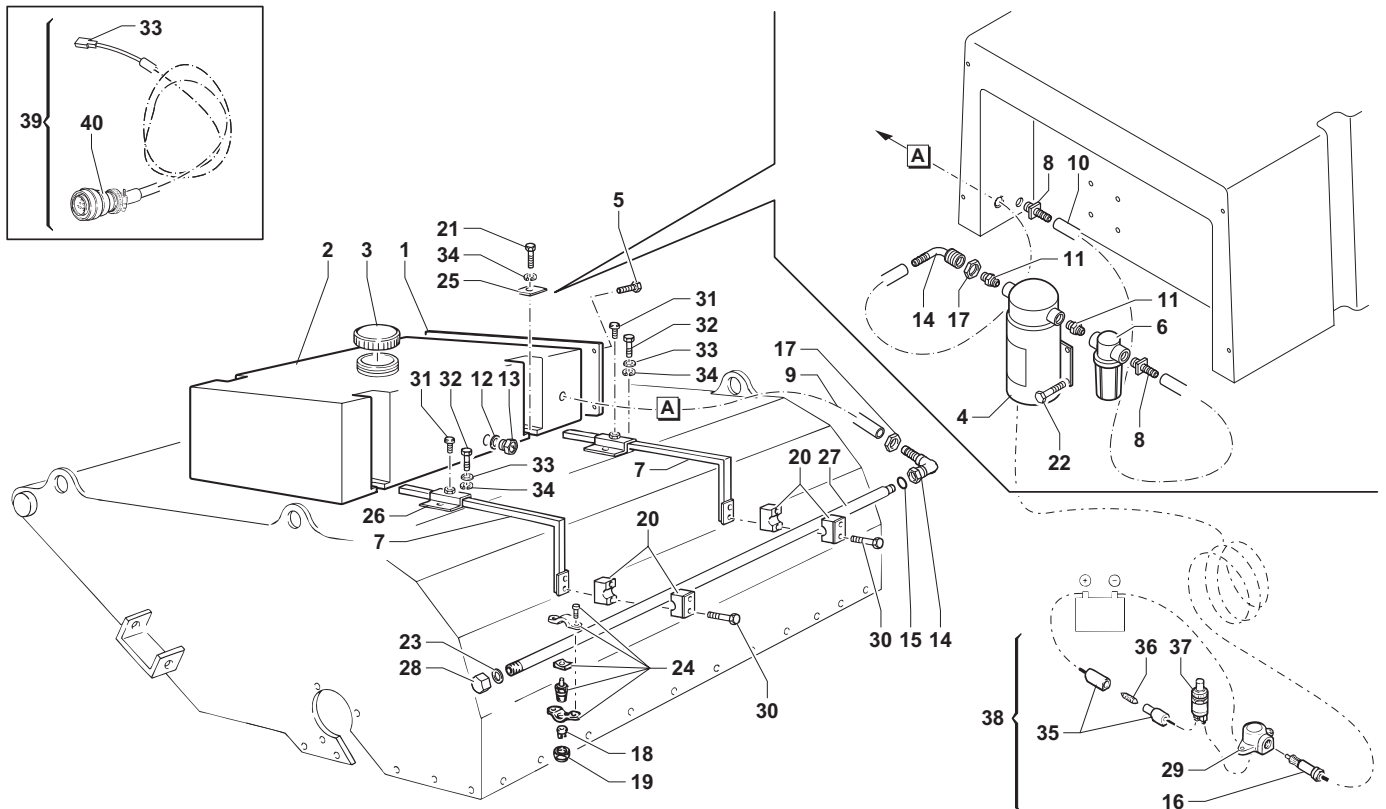

Rif.	CODICE	Descrizione	Description	Designation	Denominaciones	NOTE
1	7020000000442	PROTEZIONE	GUARD	PROTECTION	PROTECCIÓN	
2	7020000000342	SERBATOIO ACQUA	TANK	RESERVOIR	DÉPÔTITO	
3	7020000000542	TAPPO SERBATOIO	PLUG	BOUCHON	TAPÓN	
4	4242000000000	POMPA	PUMP	POMPE	BOMBA	
5	4006004006210	VITE	SCREW	VIS	TORNILLO	
6	4270001201000	FILTRO	FILTER	FILTRE	FILTRO	
7	3105000000000	SUPPORTO TUBOLARE	SUPPORT	SUPPORT	SOPORTE	
8	4270001100900	RACCORDO PORTAGOMMA	PIPE FITTING	RACCORD DE TUYAU	CONEXIÓN	
9	4270001300000	TUBO FLESSIBILE	FLEXIBLE HOSE	TUYAU FLEXIBLE	TUBO FLEXIBLE	
10	4270001300100	TUBO FLESSIBILE	FLEXIBLE HOSE	TUYAU FLEXIBLE	TUBO FLEXIBLE	
11	4206012001042	NIPPLES	PIPE FITTING	RACCORD DE TUYAU	CONEXIÓN	
12	4120000012000	GUARNIZIONE	SEAL	JOINT	GUARNICIÓN	
13	4261012000000	INDICATORE DI LIVELLO	LEVEL INDICATOR	INDICATEUR NIVEAU	INDICADOR DE NIVEL	
14	4270000501000	RACCORDO PORTAGOMMA	PIPE FITTING	RACCORD DE TUYAU	CONEXIÓN	
15	4270000900000	GUARNIZIONE O.R.	SEAL	JOINT	GUARNICIÓN	
16	4290020000000	SPINA	PLUG	FICHE	ENCHUFE	
17	4270000401000	GHIERA	RING NUT	EMBOUT	ABRAZADERA	
18	4270000300000	UGELLO	NOZZLE	BUSE	BOQUILLA	
19	4270000200000	GHIERA	RING NUT	EMBOUT	ABRAZADERA	
20	4231000002000	MORSETTO FERMATUBO	RETAINER PIPE	ARRET TUBE	RETEN TUBO	
21	4001010060210	VITE	SCREW	VIS	TORNILLO	
22	4005006030210	VITE	SCREW	VIS	TORNILLO	
23	4270000800900	GUARNIZIONE	SEAL	JOINT	GUARNICIÓN	
24	4270000100000	KIT PORTA UGELLI	KIT	KIT	KIT	
25	70000A0050104	RONDELLA	WASHER	RONDELLE	ARANDELA	
26	3106000000000	STAFFA	BRACKET	ETRIER	ESTRIBO	
27	4270000000000	TUBO DISTRIB. MANTA 1400/1550/1680	HOSE	TUYAU	TUBO	
27	42700000000100	TUBO DISTRIB. MANTA 1800	HOSE	TUYAU	TUBO	
27	42700000000300	TUBO DISTRIB. MANTA 1100/1250	HOSE	TUYAU	TUBO	
27	42700000000200	TUBO DISTRIB. MANTA 2100	HOSE	TUYAU	TUBO	
27	42700000000400	TUBO DISTRIB. MANTA 2500	HOSE	TUYAU	TUBO	
28	4270000700900	TAPPO	PLUG	BOUCHON	TAPÓN	
29	4290010000000	PRESA	SOCKET	PRISE	TOMA	
30	4005006030210	VITE	SCREW	VIS	TORNILLO	

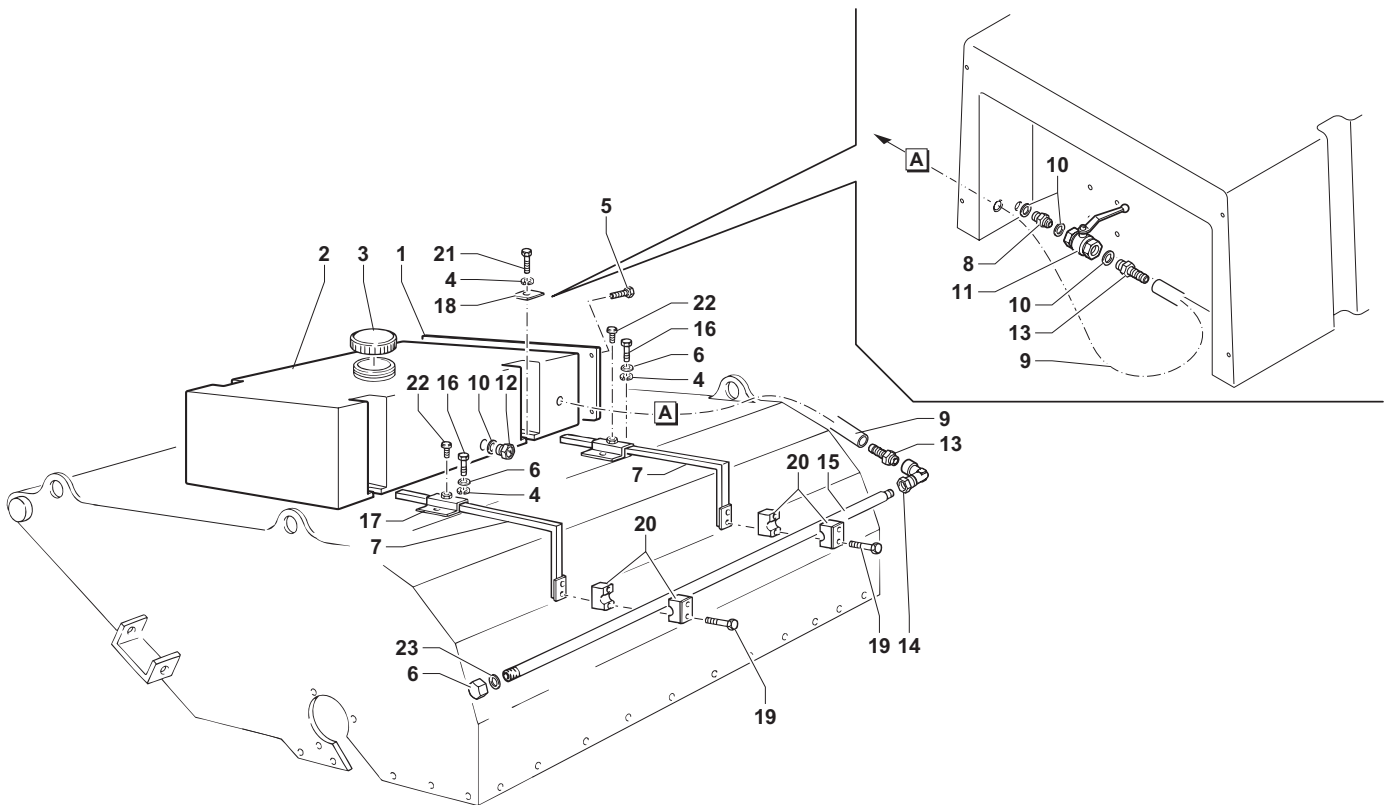

Rif.	CODICE	Descrizione	Description	Designation	Denominaciones	NOTE
1	7020000000442	PROTEZIONE	GUARD	PROTECTION	PROTECCIÓN	
2	7020000000342	SERBATOIO ACQUA	TANK	RESERVOIR	DEPÓSITO	
3	7020000000542	TAPPO SERBATOIO	PLUG	BOUCHON	TAPÓN	
4	4032010000205	RONDELLA GROWER	SPRING WASHER	RONDELLE ÉLASTIQUE	ARANDELA ELÁSTICA	
5	4006004006210	VITE	SCREW	VIS	TORNILLO	
6	4270000700900	TAPPO	PLUG	BOUCHON	TAPÓN	
7	3105000000000	SUPPORTO TUBOLARE	SUPPORT	SUPPORT	SOPORTE	
8	4270006010000	NIPPLES	PIPE FITTING	RACCORD DE TUYAU	CONEXIÓN	
9	4270001700000	TUBO FLESSIBILE	FLEXIBLE HOSE	TUYAU FLEXIBLE	TUBO FLEXIBLE	
10	4120000012000	GUARNIZIONE	SEAL	JOINT	GUARNICIÓN	
11	4151000001200	RUBINETTO	TAP	ROBINET	GRIFO	
12	4261012000000	INDICATORE DI LIVELLO	LEVEL INDICATOR	INDICATEUR NIVEAU	INDICADOR DE NIVEL	
13	4270001600000	RACCORDO PORTAGOMMA	PIPE FITTING	RACCORD DE TUYAU	CONEXIÓN	
14	4270001800000	RACCORDO PORTAGOMMA	PIPE FITTING	RACCORD DE TUYAU	CONEXIÓN	
15	4270000010000	TUBO DISTRIB. MANTA 1400/1550/1680	HOSE	TUYAU	TUBO	
15	4270000010010	TUBO DISTRIB. MANTA 1800	HOSE	TUYAU	TUBO	
15	4270000010030	TUBO DISTRIB. MANTA 1100/1250	HOSE	TUYAU	TUBO	
15	4270000010040	TUBO DISTRIB. MANTA 2500	HOSE	TUYAU	TUBO	
15	4270000010020	TUBO DISTRIB. MANTA 2100	HOSE	TUYAU	TUBO	
16	4001010025210	VITE	SCREW	VIS	TORNILLO	
17	3106000000000	STAFFA	BRACKET	ETRIER	ESTRIBO	
18	70000A0050104	RONDELLA	WASHER	RONDELLE	ARANDELA	
19	4005006030210	VITE	SCREW	VIS	TORNILLO	
20	4231000002000	MORSETTO FERMATUBO	RETAINER PIPE	ARRET TUBE	RETEN TUBO	
21	4001010060210	VITE	SCREW	VIS	TORNILLO	
22	4022010030210	VITE	SCREW	VIS	TORNILLO	
23	4270000800900	GUARNIZIONE	SEAL	JOINT	GUARNICIÓN	

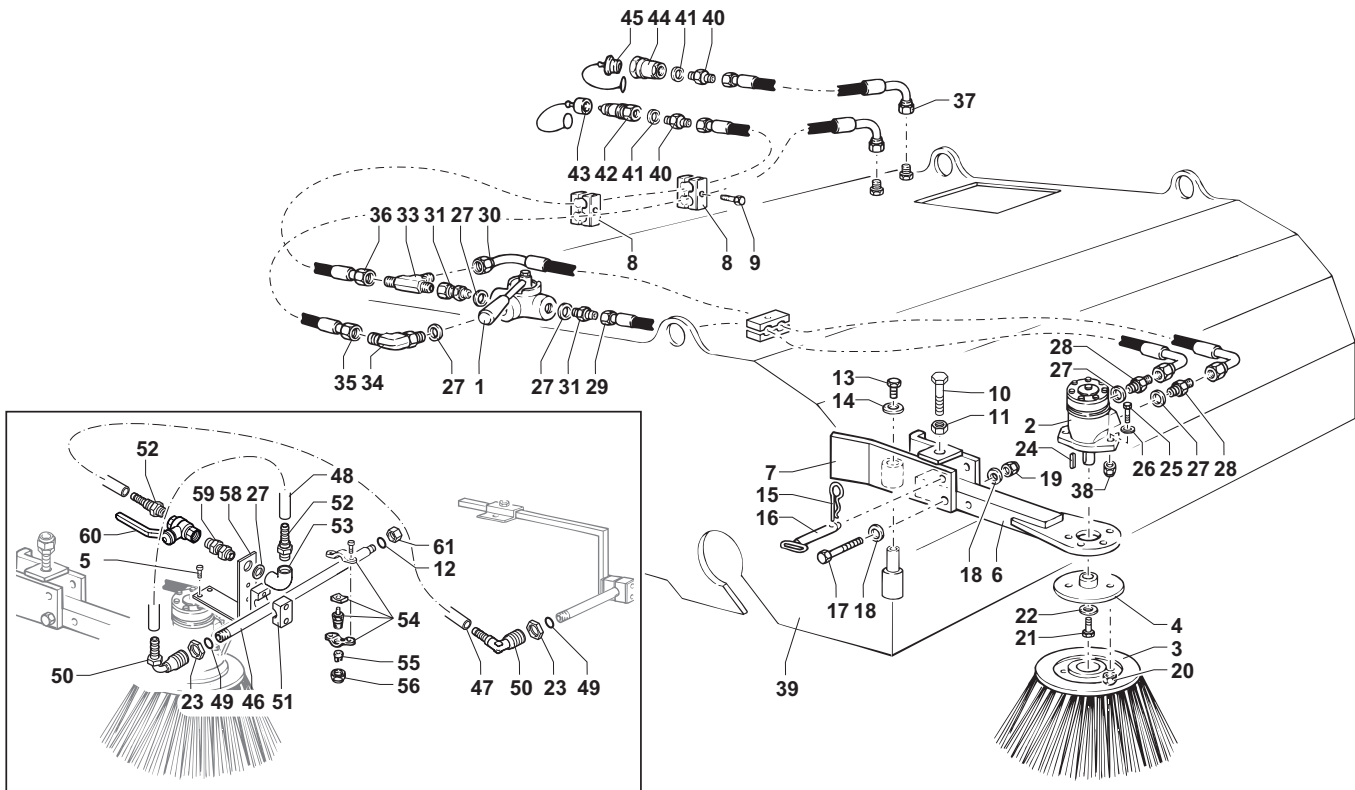

Rif.	CODICE	Descrizione	Description	Designation	Denominaciones	NOTE
1	4150000100000	RUBINETTO A TRE VIE	BALL TAP 3 WAY BALL TAPS	ROBINET A SPHERE A 3 VOIES	DESUIADOR DE 3 VIAS	
2	4171020000000	MOTORE SPAZZOLA LATERALE	MOTOR	MOTEUR	MOTOR	
3	4256000000030	SPAZZOLA SETOLE ACCIAIO	BRUSH	BALAI	CEPILLO	
3	4256000000040	SPAZZOLA SETOLE POLIPROPILENE	BRUSH	BALAI	CEPILLO	
4	6200000000099	FLANGIA	FLANGE	BRIDE	BRIDA	
5	4001008075210	VITE	SCREW	VIS	TORNILLO	
6	3107000000000	SUPPORTO MOTORE	SUPPORT	SUPPORT	SOPORTE	
7	3108000000000	STAFFA	BRACKET	ETRIER	ESTRIBO	
8	4231000002501	MORSETTO FERMATUBO	RETAINER PIPE	ARRET TUBE	RETEN TUBO	
9	4001008045210	VITE	SCREW	VIS	TORNILLO	
10	4001014100210	VITE	SCREW	VIS	TORNILLO	
11	4013014000205	DADO	NUT	ECROU	TUERCA	
12	4270000800900	GUARNIZIONE O.R.	SEAL	JOINT	GUARNICIÓN	
13	4006010016210	VITE	SCREW	VIS	TORNILLO	
14	6016110050016	RONDELLA PIANA SVASATA	WASHER	RONDELLE	ARANDELA	
15	4039003000200	SPINA A "R"	COTTER PIN	GOUPILLE	CLAVIJA	
16	6109121310099	PERNO	PIN	PIVOT	PERNO	
17	4001016110210	VITE	SCREW	VIS	TORNILLO	
18	4030016000205	RONDELLA PIANA	WASHER	RONDELLE	ARANDELA	
19	4016016000205	DADO AUTOBLOCCANTE	SELF-LOCKING NUT	ECROU DE SURETE	TUERCA AUTOTRABADORA	
20	4016012000205	DADO AUTOBLOCCANTE	SELF-LOCKING NUT	ECROU DE SURETE	TUERCA AUTOTRABADORA	
21	4003008025210	VITE	SCREW	VIS	TORNILLO	
22	6016080050016	RONDELLA	WASHER	RONDELLE	ARANDELA	
23	4270000401000	GHIERA	RING NUT	EMBOUT	ABRAZADERA	
24	4043080703002	CHIAVETTA	KEY	CLAVETTE	CHAVETA	
25	4001012045210	VITE	SCREW	VIS	TORNILLO	
26	4030012000205	RONDELLA PIANA	WASHER	RONDELLE	ARANDELA	
27	4120000012000	RONDELLA DI TENUTA	WASHER	RONDELLE	ARANDELA	
28	4206012005310	NIPPLES	PIPE FITTING	RACCORD DE TUAYU	CONEXIÓN	
29	5242480051203	TUBO FLESSIBILE	FLEXIBLE HOSE	TUYAU FLEXIBLE	TUBO FLEXIBLE	
30	5242482051403	TUBO FLESSIBILE	FLEXIBLE HOSE	TUYAU FLEXIBLE	TUBO FLEXIBLE	
31	4200010502000	NIPPLES	PIPE FITTING	RACCORD DE TUAYU	CONEXIÓN	
33	4200035000500	RACCORDO A "T"	PIPE FITTING	RACCORD DE TUAYU	CONEXIÓN	
34	4200020101800	RACCORDO 90°	PIPE FITTING	RACCORD DE TUAYU	CONEXIÓN	



SPAZZOLA LATERALE
SIDE BRUSH
BALAI LATÉRAL
CEPILLO LATERAL

Spazzatrice "Manta"
Sweeper "Manta"
Balayeuse "Manta"
Barredora "Manta"

TAV. 6.0

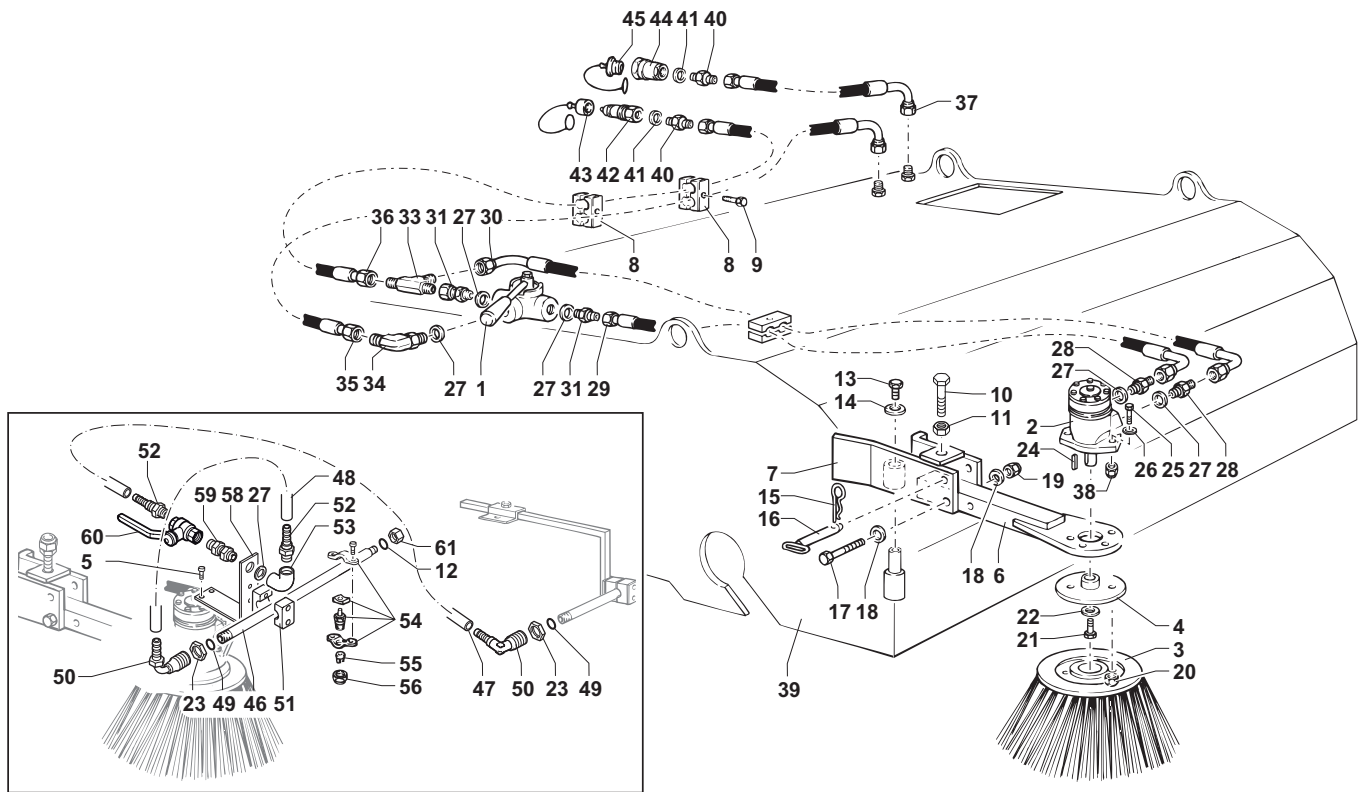

Rif.	CODICE	Descrizione	Description	Designation	Denominaciones	NOTE
35		TUBO FLESSIBILE	FLEXIBLE HOSE	TUYAU FLEXIBLE	TUBO FLEXIBLE	
36		TUBO FLESSIBILE	FLEXIBLE HOSE	TUYAU FLEXIBLE	TUBO FLEXIBLE	
37	5242480481903	TUBO FLESSIBILE	FLEXIBLE HOSE	TUYAU FLEXIBLE	TUBO FLEXIBLE	
39	3100000000601	CARTER MANTA 1100	PROTECTION CASING	CARTER	CÁRTER	
39	3100000000701	CARTER MANTA 1250	PROTECTION CASING	CARTER	CÁRTER	
39	3100000000801	CARTER MANTA 1400	PROTECTION CASING	CARTER	CÁRTER	
39	3100000000901	CARTER MANTA 1550	PROTECTION CASING	CARTER	CÁRTER	
39	310000001201	CARTER MANTA 1680	PROTECTION CASING	CARTER	CÁRTER	
39	3100000001001	CARTER MANTA 1800	PROTECTION CASING	CARTER	CÁRTER	
39	310000001101	CARTER MANTA 2100	PROTECTION CASING	CARTER	CÁRTER	
40	4206012005310	RACCORDO	PIPE FITTING	RACCORD DE TUAYU	CONEXIÓN	
40	420602000800	RACCORDO	PIPE FITTING	RACCORD DE TUAYU	CONEXIÓN	HIGH FLOW
41	412000012000	RONDELLA DI TENUTA	WASHER	RONDELLE	ARANDELA	
41	412000034000	RONDELLA DI TENUTA	WASHER	RONDELLE	ARANDELA	HIGH FLOW
42	4150000343000	INNESTO RAPIDO M.	MALE QUICK COUPLING	COUPLEUR RAPIDE MÂLE	ENCHUFE RÁPIDO MACHO	
42	4150000305000	INNESTO RAPIDO M.	MALE QUICK COUPLING	COUPLEUR RAPIDE MÂLE	ENCHUFE RÁPIDO MACHO	HIGH FLOW
43	4280100343100	TAPPO FEMMINA	PLUG	BOUCHON	TAPÓN	
43	4280100345100	TAPPO FEMMINA	PLUG	BOUCHON	TAPÓN	HIGH FLOW
44	4150000343100	INNESTO RAPIDO F.	FEMALE QUICK COUPLING	COUPLEUR RAPIDE FEMELLE	ENCHUFE RÁPIDO HEMBRA	
44	4150000345100	INNESTO RAPIDO F.	FEMALE QUICK COUPLING	COUPLEUR RAPIDE FEMELLE	ENCHUFE RÁPIDO HEMBRA	HIGH FLOW
45	4280100343000	TAPPO MASCHIO	PLUG	BOUCHON	TAPÓN	
45	4280100345000	TAPPO MASCHIO	PLUG	BOUCHON	TAPÓN	HIGH FLOW
46	427000010050	TUBO DISTRIBUZ.	HOSE	TUYAU	TUBO	
47	4270001300000	TUBO FLESSIBILE	FLEXIBLE HOSE	TUYAU FLEXIBLE	TUBO FLEXIBLE	
48	4270001300400	TUBO FLESSIBILE	FLEXIBLE HOSE	TUYAU FLEXIBLE	TUBO FLEXIBLE	
49	4270000800900	GUARNIZIONE O.R.	SEAL	JOINT	GUARNICIÓN	
50	4270000501000	RACCORDO PORTAGOMMA	PIPE FITTING	RACCORD DE TUAYU	CONEXIÓN	
51	4231000002000	MORSETTO FERMATUBO	RETAINER PIPE	ARRET TUBE	RETEN TUBO	
52	4270001100900	RACCORDO PORTAGOMMA	PIPE FITTING	RACCORD DE TUAYU	CONEXIÓN	
53	4270001800000	RACCORDO	PIPE FITTING	RACCORD DE TUAYU	CONEXIÓN	
54	4270000100000	KIT PORTA UGELLI	KIT	KIT	KIT	
55	4270000300000	UGELLO	NOZZLE	BUSE	BOQUILLA	
56	4270000200000	GHIERA	RING NUT	EMBOUT	ABRAZADERA	
58	7000030056600	SUPPORTO	SUPPORT	SUPPORT	SOPORTE	

Spazzatrice "Manta"

TAV. 6.0

OPTIONAL "HD"

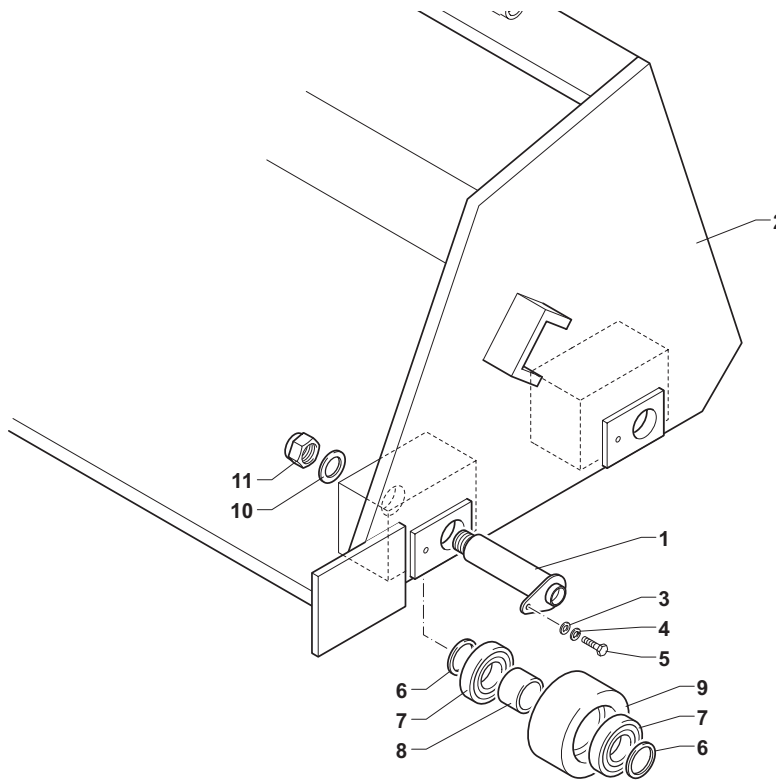

Rif.	CODICE	Descrizione	Description	Designation	Denominaciones	NOTE
1	3112000000000	PERNO	PIN	PIVOT	PERNO	fino a matr. 2852
1	3112000010000	PERNO	PIN	PIVOT	PERNO	da matr. 2878
2	3113000000000	BENNA RACCOLTA MANTA 1100	BUCKET	BENNE	CUCIARA	
2	3113000000100	BENNA RACCOLTA MANTA 1250	BUCKET	BENNE	CUCIARA	
2	3113000000200	BENNA RACCOLTA MANTA 1400	BUCKET	BENNE	CUCIARA	
2	3113000000300	BENNA RACCOLTA MANTA 1550	BUCKET	BENNE	CUCIARA	
2	3113000000600	BENNA RACCOLTA MANTA 1680	BUCKET	BENNE	CUCIARA	
2	3113000000400	BENNA RACCOLTA MANTA 1800	BUCKET	BENNE	CUCIARA	
2	3113000000500	BENNA RACCOLTA MANTA 2100	BUCKET	BENNE	CUCIARA	
3	4030008000205	RONDELLA PIANA	PLAIN WASHER	RONDELLE PLANE	ARANDELA LLANA	
4	4032008000235	RONDELLA ELASTICA	SPRING WASHER	RONDELLE ELASTIQUE	ARANDELA ELASTICA	
5	4001008020210	VITE	SCREW	VIS	TORNILLO	
6	6016300030016	DISTANZIALE	SPACER	ENTRETOISE	SEPARADOR	
7	4053030001000	CUSCINETTO	BEARING	PALIER	COJINETE	
8	6016300480016	DISTANZIALE	SPACER	ENTRETOISE	SEPARADOR	
9	6017300740001	RUOTA	WHEEL	ROUE	RUEDA	
10	4030027000205	RONDELLA	WASHER	RONDELLE	ARANDELA	fino a matr. 2852
10	4030024000205	RONDELLA	WASHER	RONDELLE	ARANDELA	da matr. 2878
11	4016027000205	DADO AUTOBLOCCANTE	STOP NUT	ECROU DE SURETE	TUERCA AUTOTRABADORA	fino a matr. 2852
11	4016024000205	DADO AUTOBLOCCANTE	STOP NUT	ECROU DE SURETE	TUERCA AUTOTRABADORA	da matr. 2878



A series of horizontal dotted lines spanning the width of the page, providing a guide for handwriting practice.



A series of horizontal dotted lines spanning the width of the page, providing a guide for handwriting practice.

